



Parker Servo Drive

Servo Drives

Installation instructions

192-011006N5
2017-09
Up from release R01-04



ENGINEERING **YOUR** SUCCESS.





Windows NT®, Windows 2000™, Windows XP™, Windows Vista, Windows 7 are trademarks of Microsoft Corporation.

EtherCAT® is a registered trademark and a patented technology of Beckhoff Automation GmbH, Germany.

CoDeSys® is a registered trademark of 3S-Smart Software Solutions GmbH.

PROFINET is a registered trademark of Profibus and PROFINET International.

Ethernet/IP is a trademark of Open DeviceNet Vendor Association.

non-warranty clause

We checked the contents of this publication for compliance with the associated hardware and software. We can, however, not exclude discrepancies and do therefore not accept any liability for the exact compliance. The information in this publication is regularly checked, necessary corrections will be part of the subsequent publications.

German Master created.

Production site:



Germany

Parker Hannifin Manufacturing Germany GmbH & Co. KG

Electromechanical & Drives Division [EME]

Robert-Bosch-Strasse 22

77656 Offenburg (Germany)

Phone: + 49 (0781) 509-0

Fax: + 49 (0781) 509-98176

Internet: www.parker.com/eme <http://www.parker.com/eme>

E-mail: EM-Motion@parker.com <mailto:EM-Motion@parker.com>

Parker Hannifin GmbH - registered office: Bielefeld HRB 35489

Management Board: Ellen Raahede Secher, Dr.-Ing. Hans-Jürgen Haas, Kees Veraart - Chairman of the board: Hansgeorg Greuner

Italy:

Parker Hannifin Manufacturing Srl

Electromechanical & Drives Division [EME]

Via C. Gounod, 1

20092 Cinisello Balsamo (Milano), Italy

Phone: + 39 (0)2 361081

Fax: + 39 (0)2 36108400

Internet: www.parker.com/eme <http://www.parker.com/eme>

E-mail: parker.italy@parker.com <mailto:parker.italy@parker.com>

Location USA:

Parker Hannifin Corporation • Electromechanical Automation

5500 Business Park Drive • Rohnert Park, CA 94928

Phone #: (800) 358-9068 • FAX #: (707) 584-3715

E-mail: CMR_help@parker.com mailto:emn_support@parker.com • Internet:

www.parker.com/emn <http://www.parker.com/emn>





Content

1. What is necessary and where to find it?	6
2. Introduction	7
2.1 Device assignment	7
2.2 Scope of delivery	7
2.3 Type identification plate PSD1-S	8
2.4 Type identification plate PSD1-M	8
2.5 Order/ type code PSD	9
2.6 Designated use	10
2.7 Packaging, transport, storage	10
2.8 For Safety Use	12
2.8.1 Explanation of the safety instructions	12
2.8.2 Working safely / qualification	12
2.8.3 General hazards	12
2.8.4 Special dangers	13
2.8.5 Cautionary Markings	14
2.8.6 Responsibility	14
2.9 Warranty conditions	14
2.10 Conditions of utilization	15
2.10.1 Conditions of utilization for CE-conform operation	15
2.10.2 CE declaration of conformity PSD1-M	18
2.10.3 CE declaration of conformity PSD1-S	19
2.10.4 Conditions of utilization for the cUL certification of PSD1-M	20
2.10.5 Conditions of utilization for the cUL certification of PSD1-S	24
2.10.6 Current on the mains PE (leakage current)	27
2.10.7 Supply networks	27
2.11 Before commissioning the drive, please observe the following:	28
3. PSD: PSD -Parker Servo Drive - Overview	29
4. Installation of the individual drive PSD1-S	30
4.1 Before commissioning the drive, please observe the following:	30
4.2 Mounting and dimensions	30
4.2.1 Mounting and dimensions PSD1-S	31
4.3 Connector overview PSD1-S	32
4.3.1 Front view (PSD1-S)	32
4.3.2 View from below (PSD1-S)	33
4.3.3 View from above (PSD1-S)	33
4.4 P14: Status LED (PSD1-S)	34
4.5 X17: Digital Inputs / outputs (PSD1-S)	35
4.5.1 Control Voltage 24 VDC PSD1-S	35
4.6 Wiring of the digital inputs and outputs	36
4.7 X63: AC Mains Supply, DC voltage supply & Connection of braking resistor (PSD1-S)	36
4.7.1 Mains connection PSD1-S	37
4.7.2 Braking operation PSD1-S	37
4.8 X52: Motor Connection (PSD1-S)	38
4.8.1 Output data PSD1-S 1/3*230 VAC	38
4.9 X51: Motor holding brake and HIPERFACE DSL® - Connection	38
4.10 X60: PC-/Diagnostic interface	39
4.11 Communication interfaces	39





4.11.1. X61, X62 Ethernet Connection 39

5. Installation of the multi-axis system PSD1-M 40

5.1 Before commissioning the drive, please observe the following: 41

5.2 Mounting and dimensions 41

5.2.1. Mounting and dimensions PSD1-M size 1 42

5.2.2. Mounting and dimensions PSD1-M size 2 43

5.3 Connector overview PSD1-M 44

5.3.1. Front view (PSD1-S)..... 44

5.3.2. View from below (PSD1-M)..... 46

5.3.3. View from above (PSD1-M)..... 47

5.4 P14 ... P16: Status LEDs of the individual axes (PSD1-M) 48

5.5 X17: Digital Inputs / outputs Axis 1 & 3 (PSD1-M) 49

5.6 X21: Digital Inputs / outputs Axis 2 & 3 (PSD1-M) 50

5.7 X18 - X19 X20 feedback connector: Assignment with incremental encoder 51

5.8 Wiring of the digital inputs and outputs 51

5.9 Motor connection / Output data 52

5.9.1. Output data servo modules PSD1-M 3*400 VAC 52

5.9.2. Output data of power output stage at PSD1-M with 3*400 VAC power supply of the mains modules 52

5.9.3. X45: Motor Connection (PSD1-M)..... 53

5.9.4. X43: Motor Connection (PSD1M_1800)..... 53

5.10 X46: Connection of motor brake (PSD1-M) 54

5.11 X44: Connection of motor brake (PSD1M_1800) 54

5.12 X48: HIPERFACE DSL® & Motor temperature sensor (PSD1-M)..... 54

5.13 Mains module PSD1-M_P 55

5.13.1. Connector overview PSD1-M_P (Mains module) 55

5.13.2. P1: Status - LEDs - indication (Mains module)..... 58

5.13.3. S2: Modes switch (Power module)..... 59

5.13.4. S3: Voltage switch (Power Module)..... 59

5.13.5. Connections of the axis system..... 59

5.13.6. X9: Control voltage 24 VDC mains module 60

5.13.7. X41 Mains supply (mains module PSD1-M_P)..... 61

5.13.8. X40: Braking resistor / Temperature switch PSD1-M_P (Power supply) 63

5.13.9. X4: Inputs / Outputs of the mains module 64

5.14 X60: PC-/Diagnostic interface..... 65

5.15 Communication interfaces..... 65

5.15.1. X61, X62 Ethernet Connection 65

6. Safe Torque Off (STO) with PSD1 66

6.1 General Description 66

6.1.1. Important Technical Terms and Explanations..... 66

6.1.2. Applications in accordance with the Regulations..... 67

6.1.3. Advantages of using the "safe torque off" safety function" STO 68

6.2 STO Operating Principle 68

6.2.1. STO principle with PSD1-S 69

6.2.2. STO principle of PSD1-S with one axis module 69

6.2.3. STO principle of PSD1-M with two axis modules 70

6.2.4. STO principle of PSD1-M with three axis modules..... 71

6.3 Notes on the STO function 72

6.4 Conditions of utilization for the STO function 73

6.5 STO delay times 74

6.6 STO Application examples 75

6.6.1. STO and SS1 function with external safety control..... 75

6.6.2. STO function without external safety control..... 77





6.7	STO function test	79
6.7.1.	STO test protocol specimen	80
6.8	Technical data STO	81

7. Accessories 82

7.1	SMH Servo Motors with HIPERFACE DSL® - Feedback	83
7.1.1.	Order code of motor cable	84
7.2	EMC measures	84
7.2.1.	Mains filter	84
7.2.2.	Motor output chokes	87
7.2.3.	Line choke	90
7.3	External braking resistors	91
7.3.1.	Overview Braking Resistors PSD1	92
7.3.2.	Braking resistor ACB-0004-01	92
7.3.3.	Braking resistor ACB-0001-01 und ACB-0002-01	93
7.3.4.	Braking resistor ACB-0003-01 for PSD1-M_P020	94
7.4	Interface Cables	95
7.4.1.	Ethernet Cables: CBD000C0-T00-T00-xxxx-00	95

8. Technical data 96

8.1	PSD1-S: Single device	96
8.1.1.	Mains connection PSD1-S	96
8.1.2.	Output data PSD1-S 1/3*230 VAC	97
8.1.3.	Control Voltage 24 VDC PSD1-S	97
8.1.4.	Braking operation PSD1-S	97
8.1.5.	Baugröße / Gewicht PSD1-S	97
8.2	PSD1-M: Multi-axes system	98
8.2.1.	Mains Connection Power module PSD1-M_P010 with line choke	98
8.2.2.	Mains connection Power module PSD1-M_P010 with line choke	98
8.2.3.	Mains Connection Power module PSD1-M_P020 without line choke	99
8.2.4.	Mains connection Power module PSD1-M_P020 with line choke	99
8.2.5.	Output data servo modules PSD1-M 3*400 VAC	100
8.2.6.	Output data of power output stage at PSD1-M with 3*400 VAC power supply of the mains modules	100
8.2.7.	Control voltage 24 VDC PSD1-M_P (mains module)	100
8.2.8.	Braking operation PSD1-M	101
8.2.9.	Dynamic braking module	101
8.2.10.	Size / Weight PSD1-M	101
8.3	Motor technologies supported	102
8.4	Feedback system HIPERFACE DSL®	102
8.5	Incremental encoder / analogue HAL sensor with 1VSS	102
8.6	Motor holding brake output	102
8.7	Digital inputs / outputs (specifications)	103
8.8	Technical data STO	103
8.9	EC directives and applied harmonized EC norms (PSD1)	104
8.10	EMC limit values PSD1	104
8.11	Insulation requirements PSD1	104
8.12	Environmental requirements PSD1	104
8.13	cUL certification	105
8.14	EtherCAT characteristics	105
8.15	PROFINET Characteristics	105
8.16	EtherNet/IP - Kenndaten	106





9. Index 107

1. What is necessary and where to find it?

Software Tool, PSD ServoManager
Field Bus Files, Downloads under http://solutions.parker.com/psd_support
CE declaration of compliance





2. Introduction

In this chapter you can read about:

• Device assignment	7
• Scope of delivery	7
• Type identification plate PSD1-S	8
• Type identification plate PSD1-M	8
• Order/ type code PSD	8
• Designated use	10
• Packaging, transport, storage	10
• For Safety Use	12
• Warranty conditions	14
• Conditions of utilization	15
• Before commissioning the drive, please observe the following:	28

2.1 Device assignment

This manual is valid for the following devices:

- PSD1-SW1200 (2 A)
- PSD1-SW1300 (5 A)
- PSD1-M_1300 (5 A)
- PSD1-M_1500 (10 A)
- PSD1-M_1600 (15 A)
- PSD1-M_1800 (30A)
- PSD1-M_2220 (2 A + 2 A)
- PSD1-M_2330 (5 A + 5 A)
- PSD1-M_2440 (8 A + 8 A)
- PSD1-M_2630 (15 A + 5 A)
- PSD1-M_3222 (2 A + 2 A + 2 A)
- PSD1-M_3433 (8 A + 5 A + 5 A)
- PSD1-MWP010 (Mains module 10 kW)
- PSD1-MWP020 (Mains module 20 kW)

2.2 Scope of delivery

Included in delivery are mating connectors for:





PSD1-S	X17 (Push-in) X51, X52, X63 (screw terminals)
PSD1-M:	X17 / X21 (Push-in) X45, X46, X48 (screw terminals) X43, X44, X48 (screw terminals for PSD1-M_1800)
PSD1-M_P:	X4 (Push-in) X9, X40, X41 (screw terminals)





2.3 Type identification plate PSD1-S



The present device type is defined by the type specification plate (on the housing):

 STO certified	Parker Hannifin Manufacturing Germany GmbH & Co KG Robert-Bosch-Straße 22 77656 Offenburg Tel. +49 (0) 781/509-0 www.parker.com/eme	
	PN: PSD1SW1200B1100000 --- ① SN: 4259420001 --- ④	
	Power Input *: ② 1 AC 230 V / 6,8 A / 50...60 Hz ⑤ 3 AC 230 V / 1,7 A / 50...60 Hz ⑦	
	Power Output *: ③ 3 AC 0-230 V (0-400 Hz) / 2 A --- ⑥	
LISTED IND. CONT. EQ. 14GZ	IP20 * Read Short Manual (DOC-0002-01) before installing	
	File No. E235342	Made in Germany
	Tested: 20.03.2017	

1	Order code of the device
2	Input voltage
3	Input Current
4	Serial Number
5	Output voltage
6	Output current
7	Output frequency
8	UL certification (corresponding to the existing logo)

2.4 Type identification plate PSD1-M

The present device type is defined by the type specification plate (on the housing):

		
1	PSD1MW3433B1100000 --- TP15049999	4
	Input Output	
2	300/750 Vdc 3x3ph 0-480V	5
3	19 Adc 8+5+5 A	6
	0-450 Hz	7
		8
	LISTED Power Conversion Equipment 14 GZ	
	READ INSTALLATION INSTRUCTION MANUAL BEFORE INSTALLING	USE COPPER WIRE RATED 60/75°C

1	Order code of the device
2	Input voltage
3	Input Current
4	Serial Number
5	Output voltage
6	Output current
7	Output frequency
8	UL certification





2.5 Order/ type code PSD

	1	2	3	4	5	6	7	8	9	10	11
Ordering example	PSD1	M	W	3	433	B	1	1	0	0	000

1	Drive family	
	PSD1	Parker Servo Drive
2	Device type	
	S	Stand-Alone 230 VAC
	M	Multi axis 400 VAC
3	Mounting type	
	W	Wall mounting
	C	Cold plate*
	P	Push through IP20*
4	Device type	
	1	1 performance level
	2	2 performance levels
	3	3 performance levels
	P	Mains modules
5	Device type	
	PSD1SW1	Stand-Alone
	200	2 A
	300	5 A
	PSD1MW1:	1 performance level
	300	5 A
	400	8 A
	600	15 A
	800	30 A
	PSD1MW2:	2 performance levels
	220	2 + 2 A
	330	5 + 5 A
	440	8 + 8 A
	630	15 + 5 A
	PSD1MW3:	3 performance levels
	222	2 + 2 + 2 A
	433	8 + 5 + 5 A
	PSD1MWP	
	010	10 kVA
	020	20 kVA
6	Technology	
	B	Basis
7	Interface	
	1	EtherCAT
	2	Field Bus configurable: PROFINET, EtherCATIN, Ethernet/IP
8	Feedback	
	1	DSL
	2	EnDat 2.2*
	3	BISS C*
	4	Resolver*
	5	Incremental encoder / analogue HAL sensor with 1 VSS***
9	Option 1	
	0	No option
	1	Functional safety viat EtherCAT*
10	Option 2	
	0	No option
11	Customized	
	000	Non customized

* in development

** in the first stage only for PSD1MV1...: Multi axes device with one powerstage





2.6 Designated use

The device is designed for operation in electric power drive systems (EN 50178). Motion sequences can be automated with this device. Several motion sequences can be combined by interconnecting several of these devices. Mutual interlocking functions must be incorporated for this purpose.

Please respect the **technical data** (see page 95)!

Exceeding / not respecting its intended use or its limits may cause danger.

- Motion sequence may not be carried out correctly which can cause personal injuries or material damages.
- The device might be destroyed what could result in fire.
- The device corresponds to EN 61800-3, i.e. it is subject to limited sale. The device can emit disturbances in certain local environments. In this case, the user is liable to take suitable measures.

2.7 Packaging, transport, storage

Packaging material and transport



Caution!

The packaging material is inflammable, if it is disposed of improperly by burning, lethal fumes may develop.

The packaging material must be kept and reused in the case of a return shipment. Improper or faulty packaging may lead to transport damages.

Make sure to transport the drive always in a safe manner and with the aid of suitable lifting equipment (**Weight** (see page 95)). Do never use the electric connections for lifting. Before the transport, a clean, level surface should be prepared to place the device on. The electric connections may not be damaged when placing the device.

First device checkup

- Check the device for signs of transport damages.
- Please verify, if the indications on the Type identification plate correspond to your requirements.
- Check if the consignment is complete.

Disposal

This product contains materials that fall under the special disposal regulation from 2010, which corresponds to the EC directory 2008/98/EC for dangerous disposal material. We recommend to dispose of the respective materials in accordance with the respectively valid environmental laws. The following table states the materials suitable for recycling and the materials which have to be disposed of separately.

Material	suitable for recycling	Disposal
metal	yes	no
Plastics	yes	no
Circuit boards	no	yes

Please dispose of the circuit boards according to one of the following methods:

- Burning at high temperatures (at least 1200°C) in an incineration plant licensed in accordance with part A or B of the environmental protection act.
- Disposal via a technical waste dump which is allowed to take on electrolytic aluminium condensers. Do under no circumstances dump the circuit boards at a place near a normal waste dump.



**Storage**

If you do not wish to mount and install the device immediately, make sure to store it in a dry and clean environment. Make sure that the device is not stored near strong heat sources and that no metal chippings can get into the device.

Please note in the event of storage >1 year: Forming the capacitors

Forming the capacitors only required with 400 VAC axis controllers and mains module PSD1-M_P

If the device was stored longer than one year, the intermediate capacitors must be re-formed!

Forming sequence:

- Remove all electric connections
- Supply the device with 230VAC single phase for 30 minutes
 - ◆ via the L1 and L2 terminals on the device or
 - ◆ with multi axis devices via L1 and L2 on the mains module PSD1-M_P.





2.8 For Safety Use

In this chapter you can read about:

• Explanation of the safety instructions.....	12
• Working safely / qualification	12
• General hazards	12
• Special dangers.....	13
• Cautionary Markings.....	14
• Responsibility	14

2.8.1. Explanation of the safety instructions



DANGER Indicates a potential risk that may result in death or severe injury.



WARNING Indicates a potential medium risk with that may result in death or severe injury.



CAUTION Indicates a potential low risk with that may result in minor or moderate injury.



NOTICE Alerts you to situations that may damage this product or other products.

2.8.2. Working safely / qualification

This device may be operated only by qualified personnel.

Qualified personnel in the sense of these operating instructions consists of:

- Persons who, by virtue to their training, experience and instruction, and their knowledge of pertinent norms, specifications, accident prevention regulations and operational relationships, have been authorized by the officer responsible for the safety of the system to perform the required task and in the process are capable of recognizing potential hazards and avoiding them (definition of technical personnel according to VDE105 or IEC364),
- who have a knowledge of first-aid techniques and the local emergency rescue services,
- who have read and will observe the safety instructions,
- who have read and observe the manual or help (or the sections pertinent to the work to be carried out).

This applies to all work relating to setting up, commissioning, configuring, programming, modifying the conditions of utilization and operating modes, and to maintenance work.

This manual and the help information must be available close to the device during the performance of all tasks.

2.8.3. General hazards

General Hazards on Non-Compliance with the Safety Instructions

The device described in this manual is designed in accordance with the latest technology and is safe in operation. Nevertheless, the device can entail certain hazards if used improperly or for purposes other than those explicitly intended. Electronic, moving and rotating components can

- constitute a hazard for body and life of the user, and
- cause material damage





2.8.4. Special dangers

DANGER

Danger!

Due to movable machine parts and high voltages, the device can pose a lethal danger. Danger of electric shock in the case of non-respect of the following instructions. The device corresponds to DIN EN 61800-3, i.e. it is subject to limited sale. The device can emit disturbances in certain local environments. In this case, the user is liable to take suitable measures.

- Check that all live terminals are secured against contact. Perilous voltage levels of up to 850V occur.
- Do not bypass power direct current.

CAUTION: Risk of electric shock

DANGER

Caution - Risk of electric shock!

Before wiring or loosening electrical connections please observe the following:



- Risk of electric shock, disconnect power before removing cover resp. disconnect the devices from the mains supply.

- **Caution!** Dangerous electrical voltage even after turning off the intermediate capacitors:

Up to 3 minutes with PSD1-S and 10 minutes with PSD1-M after switching off mains supply, dangerous voltages may still be present.

Please check that no voltages are present (<50 V) at the output terminals DC+ and DC- of PSD1-S: X63/3 & X63/5 and with PSD1-M: Bus HV DC - 3 & 5. rail.

- The device must be permanently grounded due to high earth leakage currents. The leakage current is greater than 3.5 mA.
- The drive motor must be grounded with a suitable protective lead.

DANGER



- The devices are equipped with high voltage DC capacitor. Before removing the protective cover, the discharging time must be awaited. After switching off the supply voltage, it may take up to 3 minutes with PSD1-S and 10 minutes with PSD1-M (up to 30 minutes with additional capacitor modules) to discharge the capacitors.

Danger of electric shock in case of non respect.

- Do never perform resistance tests with elevated voltages (over 690V) on the wiring without separating the circuit to be tested from the drive.
- Please exchange devices only in currentless state and, in an axis system, only in a defined original state.
- If the axis controller is replaced, it is absolutely necessary to transfer the configuration determining the correct operation of the drive to the device before the device is put into operation. Depending on the operation mode, a machine zero run will be necessary.
- The device contains electrostatically sensitive components. Please heed the electrostatic protection measures while working at/with the device as well as during installation and maintenance.



2.8.5. Cautionary Markings



WARNING

Ignoring of the following instructions will result in personal injury or material damage.

- The heat dissipator can reach very high temperatures (>70°C)
- Do never perform resistance tests with elevated voltages (over 690V) on the wiring without separating the circuit to be tested from the drive.
- Please exchange devices only in currentless state and, in an axis system, only in a defined original state.
- If the axis controller is replaced, it is absolutely necessary to transfer the configuration determining the correct operation of the drive to the device before the device is put into operation. Depending on the operation mode, a machine zero run will be necessary.
- The device contains electrostatically sensitive components. Please heed the electrostatic protection measures while working at/with the device as well as during installation and maintenance.
- Never carry out high voltage resistance tests at lines without disconnecting the drive from the power supply you need to check.
- Provide protection and/or additional safety systems in order to prevent personal injury and material damage. Always care for sufficient ventilation.
- All control and signal terminals guaranty safe extra-low voltages (SELV), i.e. they are protected by a double isolation. Make sure the complete external wiring is approved for the highest system voltage.
- The user is responsible for protective covers and/or additional safety measures in order to prevent damages to persons and electric accidents.

2.8.6. Responsibility

Fitters and operators of any machine or systems are responsible for ensuring that, in case of failure of a device or component, the drive and therefore the machine or system is rendered safe. In doing so, people must not be endangered.

The here-in described technical data, processes and circuits are merely a general guidance and may not be suitable for the user's specified application. We cannot guaranty the suitability for certain applications of the device described in this manual.

2.9 Warranty conditions

- The device must not be opened.
- Do not make any modifications to the device, except for those described in the manual.
- Make connections to the inputs, outputs and interfaces only in the manner described in the manual.
- Fix the devices according to the **mounting instructions**. (see page 30)
We cannot provide any guarantee for other mounting methods.

Note on exchange of options

Device options must be exchanged in the factory to ensure hardware and software compatibility.

- When installing the device, make sure the heat dissipators of the device receive sufficient air and respect the recommended mounting distances of the devices with integrated ventilator fans in order to ensure free circulation of the cooling air.
- Make sure that the mounting plate is not exposed to external temperature influences.





2.10 Conditions of utilization

In this chapter you can read about:

- Conditions of utilization for CE-conform operation 15
- CE declaration of conformity PSD1-M 18
- CE declaration of conformity PSD1-S 19
- Conditions of utilization for the cUL certification of PSD1-M..... 20
- Conditions of utilization for the cUL certification of PSD1-S 24
- Current on the mains PE (leakage current)..... 27
- Supply networks 27

2.10.1. Conditions of utilization for CE-conform operation

- Industry and trade -

The EC guidelines for electromagnetic compatibility 2014/30/EU and for electrical operating devices for utilization within certain voltage limits 2014/35/EU are fulfilled when the following boundary conditions are observed:

Operation of devices only in the state in which they are delivered.

Contact protection mating plug

In order to ensure contact protection, all mating plugs must be present on the device connections even if they are not wired.

Instructions for this manual

Please respect the specifications of the manual resp. of the help function, especially the technical characteristics (mains connection, circuit breakers, output data, ambient conditions,...).

2.10.1.1 Mains filter for use in industrial areas

A mains filter is required in the mains input line if the motor cable exceeds a certain length. Filtering can be provided plant specifically or separately for each device respectively for each axis combination.

Use of the devices in the industrial area (limit values class C3 in accordance with EN 61800-3)

The following mains filters are available for independent utilization:

Device:	Limit value class	Axis system with motor cable / Single-axis	Mains filter Order No.:
PSD1-M_P010	C3	< 6 x 10 m	ECP-0003-01 (see page 86)
PSD1-M_P010	C3	< 6 x 50 m	ECP-0003-02 (see page 86)
PSD1-M_P020	C3	< 6 x 50 m	ECP-0003-03 (see page 86)
PSD1-S	C3	< 10 m	no mains filter
PSD1-S (single phase supply)	C3	> 10 m	ECP-0001-01 (see page 85)
PSD1-S (3-phase supply)	C3	> 10 m	ECP-0002-01 (see page 85)

In general, the connection mains filter - device shall be as short as possible.

unshielded: < 0.5 m

shielded: < 5 (screen must be connected to ground - e.g. ground-control cabinet)





2.10.1.2 Motor and feedback cable requirements

- Operation of the devices only with motor and feedback cables whose plugs contain a special full surface area screening.
- Maintain the shielding as close as possible to the cable-end (max distance 8 cm).
- Earth empty wires in the cable.

<100 m per axis (the cable must not be rolled up!).

The entire length of the motor cable per axis combination may not exceed 300 m.

PSD1-M

For motor cables >20 m a motor output choke is required for PSD1-M devices:

- **ECM-0004-01** (see page 88) (max. 6.3 A nominal motor current)
- **ECM-0001-01** (see page 88) (max. 16 A nominal motor current)
- **ECM-0002-01** (see page 88) (max. 30 A nominal motor current)

PSD1-S

For motor cables >50 m a motor output choke is required for PSD1-S devices:

- **ECM-0005-01** (see page 87) (max. 7 A motor nominal current)

Shielding connection of the motor cable

The cable must be fully-screened and connected to the device housing. Use the cable clamps/shield connecting terminals furnished with the device.

The shield of the cable must also be connected with the motor housing. The fixing (via plug or screw in the terminal box) depends on the motor type.

2.10.1.3 Cable installation:

- Signal lines and power lines should be installed as far apart as possible; cross points 90°.
- Signal lines should never pass close to excessive sources of interference (motors, transformers, contactors etc.).
- Do not place mains filter output cable parallel to the load cable.
- Lines must lead along conductive, grounded metal surfaces as closely as possible.

2.10.1.4 Motors

Operation with standard motors.

2.10.1.5 Protective earth



WARNING

Additionally to the ground connection at the power mains connection, establish a ground connection via the **grounding screw** (see page 46, see page 57, see page 33) on the device bottom by means of a copper cable with the same section. In case there is not earth connection at the mains connection, the wire used must have a minimum diameter of 10 mm².

The connection to the central earth rail should be as short as possible. The minimum required width of the central earth rail depends on the length of the grounding cable:

Length [m]	Width [mm]	Strength [mm]
0.5	20	6
1	40	6
1.5	50	6

- Pay close attention to the overall grounding of the complete system.
- With several mounting plates: Interconnect several mounting plates using copper rails or copper band.
- Pay attention to the ground connection between the control cabinet and machine.
- Earth control transformer thoroughly (for 24 VDC). Use a transformer with a metal socket and pay attention to provide for good conductive contact on mounting plate.





2.10.1.6 **Grounding requirements**

Connect the filter housing and the device to the cabinet frame, making sure that the contact area is adequate and that the connection has low resistance and low inductance by using an 3 mm steel plate (galvanized).

Never mount the filter housing and the device on paint-coated surfaces!

2.10.1.7 **Control requirements**

Use only with aligned controller (to avoid control loop oscillation).

2.10.1.8 **Accessories**

Make sure to use only the accessories recommended by Parker.

2.10.1.9 **Notes on the use in domestic environments**

NOTICE

This is restricted operation category product according to EN 61800-3. This product can cause high-frequency disturbance in domestic areas. Users are asked to take suitable action if this proves to be the case.





2.10.2. CE declaration of conformity PSD1-M



Parker Hannifin Manufacturing S.r.l.
Via Gounod, 1
20092 Cinisello Balsamo (MI) – Italy

EU DECLARATION OF CONFORMITY

Document: **DOC-0004-01-R020**

Manufacturer **Parker Hannifin Manufacturing S.r.l.**
Address **Via Gounod, 1**
20092 Cinisello Balsamo (MI)
ITALY

declares under sole responsibility compliance of the following products

Product **Drive**
Product name **PSD1M series**

with the

Low Voltage Directive 2014/35/EU

Applied harmonized standards
EN 61800-5-1:2007
Adjustable speed electrical power drive systems
Part 5-1: Safety requirements - Electrical, thermal and energy

EMC Directive 2014/30/EU

Applied harmonized standards
EN 61800-3:2004 + A1:2012
Adjustable speed electrical power drive systems
Part 3: EMC product standard including specific test methods.

Notes:

These products must be installed and operated with reference to the instructions in the Product Manual.
All instructions, warnings and safety information of the Product Manual must be adhered to.

The products are components to be incorporated into machinery and may not be operated alone. The complete machinery or installation may only be put into service when the safety considerations of the Machinery Directive 2006/42/EC are fully adhered to.

CE mark affixed date: 2015-04

Cinisello Balsamo, 2016-04-20

Giorgio Colnaghi, Operations Manager
Authorized for technical documentation

20092 Cinisello Balsamo (MI) – Italy – Via Gounod, 1 – Tel. +39 02361081 – Fax +39 0236108400
SEDE LEGALE: 20094 Corsico (MI) – Italy – Via Privata Archimede, 1 – Tel. +39 0245192.1 – Fax +39 024479340
internet: www.parker-eme.com E-mail: italy_parker@parker.com
Isr.: R.I. Mi N. 125728, R.E.A. Mi N. 682188 – Cap. Soc. Euro 1.230.000 – P.I. / C.F. / VAT (IT) 08254200010



**2.10.3. CE declaration of conformity PSD1-S**

Parker Hannifin Manufacturing Germany GmbH & Co. KG
Automation Group, Electromechanical & Drives Division Europe
Robert-Bosch-Straße 22
D-77656 Offenburg

Tel.: +49 (0) 781-509-0
Fax.: +49 (0) 781-509-98176
www.parker.com/eme

EU DECLARATION OF CONFORMITYDocument: **DOC-0003-01-R040**

Manufacturer **Parker Hannifin Manufacturing Germany GmbH & Co. KG**
Address **Robert-Bosch-Straße 22**
77656 Offenburg
Deutschland

declares under sole responsibility compliance of the following products

Product **Drive of the series PSD1S**
Product name **PSD1SW1200 and PSD1SW1300**

with the

Low Voltage Directive 2014/35/EU

Applied harmonized standards
EN 61800-5-1:2007
Adjustable speed electrical power drive systems
Part 5-1: Safety requirements- Electrical, thermal and energy

EMC Directive 2014/30/EU

Applied harmonized standards
EN 61800-3:2004 + A1:2012
Adjustable speed electrical power drive systems
Part 3: EMC product standard including specific test methods.

Machinery Directive 2006/42/EC (Appendix IV)

Applied harmonized standards
EN 61800-5-2:2007
Adjustable speed electrical power drive systems
Part 5-2: Safety requirements – Functional
EN ISO 13849-1:2015
Safety of Machinery – Safety-related parts of control systems
Part 1: General principles for design

RoHS Directive 2011/65/EU

Applied harmonized standards
EN 50581:2012
Technical documentation for the assessment of electrical and electronic products with respect to the restriction of hazardous substances

Notes:

These products must be installed and operated with reference to the instructions in the Product Manual.
All instructions, warnings and safety information of the Product Manual must be adhered to.

The products are components to be incorporated into machinery and may not be operated alone. The complete machinery or installation may only be put into service when the safety considerations of the Machinery Directive 2006/42/EC are fully adhered to.

CE mark affixed date: 2015-06

Offenburg, 2017-07-21

Jürgen Killius, Operations Manager
Person authorized to compile technical file



Seite / Page 2 von / of 3

Parker Hannifin Manufacturing Germany GmbH & Co. KG
Sitz: Bielefeld HRA 15699
USt.-IdNr.: DE 277 235 745
Steuernummer: 349 5747 2105

Commerzbank Offenburg
BLZ 664 400 84
Konto-Nr. 45 0 19 12 00
BIC/Swift-Code: COBADEFF
IBAN DE95 6644 0084 0450 1912 00

Persönlich haftende Gesellschafterin: Parker Hannifin GmbH
Sitz: Bielefeld – Amtsgericht Bielefeld HRB 35489
Geschäftsführung:
Dr.-Ing. Hans-Jürgen Haas, Ellen Raahede Secher, Günter Schrank, Kees Verraart
Vorsitzender des Aufsichtsrates: Hansgeorg Greuner





2.10.4. Conditions of utilization for the cUL certification of PSD1-M

[In diesem Kapitel finden Sie](#)

- UL certification..... 20
- Installations- & Environmental Characteristics PSD1-M 20
- PSD1-M Installations- & Environmental Characteristics 21
- Conditions of utilization for CSA certification 23

2.10.4.1 UL certification

Category	Specifications
Certified	E-File_No.: E235342 The UL certification is only valid if the type plate of the device shows the "UL" -sign. 
PSD1-M:	UL508C, 3rd Edition, power supply load revision November 9th, 2010. C22.2 No.274-13, 1st Edition, issued March, 2013

2.10.4.2 Installations- & Environmental Characteristics PSD1-M

- The devices are only to be installed in a pollution degree 2 environment (maximum).
- Maximum Surrounding Air Temperature 40 °C.
- The devices must be appropriately protected (e.g. by a switching cabinet). - Open type equipment.
- Temperature rating of field installed conductors shall be at least 60°C. Do only use copper lines.
Do only use the Parker cables available under **Accessories** (see page 82) or assemble the cables according to the specified regulations.
- Control voltage supply (24 VDC) only permissible with "class 2" power supply.
- The devices are internally protected against overvoltage in compliance with UL508C.
- The drive modules are equipped with a current limit. Values for maximum device current and maximum motor current can be set via PSD ServoManager (Chapter resp. Menu Limit values & Motor Characteristics).
- PSD1-M is intended for use in motors with internal or external motor protection. Integral motor overload protection is not available.
- Motor overheating protection is not supported and must externally be realized.
- Integral solid state short circuit protection does not provide branch circuit protection. Branch circuit protection must be provided in accordance with the Manufacturer Instructions, National Electrical Code and any additional local codes
- Protective earth of the motor must be connected to protective earth of the device. Please observe that ground on PSD1 - motor connector is, according to NEC NFPA 70, a functional earth and not a protective earth.





2.10.4.3 PSD1-M Installations- & Environmental Characteristics

- Please observe that the operation of the PSD1-M axis modules is only permitted via the Parker Power Module PSD1-M_P. Furthermore Power Modules PSD1-M_P must only be used with PSD1-M axis modules.
The UL certification does not cover individual devices but only the axis system of the PSD1-M_P and PSD1-M_P mains module.
- Dynamic braking unit

Data of the integrated dynamic brake module PSD1-M_P

Category	Specifications			
	Maximum current		Max. Duty Cycle	Minimum resistance value
	Peak	Duration		
PSD1-M_P010	28.8 A	4.27 A (500 W)	2.2 % (@60 s)	27 Ω
		7.5 A (1500 W)	6.7 % (@60 s)	
PSD1-M_P020	78.0 A	7.06 A (500 W)	0.82 % (@60 s)	10 Ω
		22.3 A (5000 W)	8.2 % (@60 s)	

- Suitable for use on a circuit capable of delivering not more than 5000 rms Symmetrical Amperes, 480 V ac +10 % maximum, when protected by Listed
 - ◆ DIVQ Circuit Breakers manufactured by ABB, Stotz-Kontakt GmbH, Mod. No. S203UP-K / 480 Vac, 25 A for PSD1-M_P010
 - or
 - ◆ R/C (JFHR2/8) Semiconductor Fuse type manufactured by Cooper Bussmann LLC, Mod. No. 170M1366 oder 170M1566D, 690 VAC, 80 A, 200 kA RMS Sym for PSD1-M_P020..
- Power supply units PSD1-M_P need a fusing on the main site (branch circuit protection) as stated below.

PSD1-M_P010

Maximum fuse rating per device	Measure for line and device protection: UL listing (DIVQ) fuses Manufacturer: ABB, Stotz-Kontakt GmbH (E212323) Model No.: S203UP-K, 1 fuse 480 VAC, 3-phase, 25 A, operating temperature 55 °C
---------------------------------------	---

PSD1-M_P020

Maximum fuse rating per device 2 special purpose fuses in line are required	Cable protection measure: MCB (K characteristic) with a rating of 50A / 4xxVAC (depending on the input voltage) Recommendation: (ABB) S203U-K50 (440VAC) Device protection measure: Circuit breakers 80A / 700VAC per supply leg in accordance with UL category JFHR2 Requirement: Bussmann 170M1366 or 170M1566D
--	--

Tightening torque of the wiring terminals



Risk of Electric Shock, wait at least 10 minutes before removing cover.





The field wiring terminals should be tightened with the torques mentioned below.
Only the supplied mating connectors must be used.

PSD1-M		2 A ... 15 A
X45 Motor	UL	up to AWG10
	CE	up to 4 mm ²
	Tightening torque	0.8 Nm 7 Lb.in
❖		❖
X46 motor brake	UL	up to AWG14
	CE	up to 1.5 mm ²
	Tightening torque	0.22 ... 0.25 Nm 1.95 ... 2.21 Lb.in
PSD1M_1800		2 A ... 30 A
X43 Motor	UL	up to AWG20-8
	CE	up to 6 mm ²
	Tightening torque	1.1 ... 1.7 Nm 11 ... 15 Lb.in
❖		❖
X44 motor brake	UL	up to AWG30-14
	CE	up to 1.5 mm ² *
	Tightening torque	0.22 ... 0.25 Nm 1.95 ... 2.21 Lb.in
Mains module		
X40: Ballast resistor	UL	up to AWG10
	CE	up to 6 mm ²
	Tightening torque	0.46 ... 0.57 Nm (M3) 4 ... 5 Lb.in
❖		❖
X41: Mains connector PSD1-M_P010	UL	up to AWG10
	CE	up to 6 mm ²
	Tightening torque	1,1 ... 1.7 Nm 11 ... 15 Lb.in
❖		❖
X41: Mains connector PSD1-M_P020	UL	up to AWG6
	CE	up to 16 mm ²
	Tightening torque	1.7 Nm 15 Lb.in
❖		❖
X9: 24 VDC Steuerspannung	UL	up to AWG10
	CE	up to 6 mm ²
	Tightening torque	1.1 ... 1.7 Nm 11 ... 15 Lb.in
❖		❖
DC Bus	UL	-
	CE	-
	Tightening torque	0.8 Nm 7 Lb.in

* max 0.5mm² ferrule with plastic sleeve





2.10.4.4 Conditions of utilization for CSA certification

External Overvoltage Protection

External overvoltage protection in accordance with Canadian Standards C22.2-No.274-13 with over-voltage protection device (VZCA2) CSA-certified.

Note the following table:

Mains module	Manufacturer	Model No (Quantity 1)	Maximum Continuous Operating Voltage (Vac)	Voltage Protection Rating (VPR)(Vpk)	Category / Nominal earth leakage current
PSD1-M_P01 0	ABB Frankreich (E322885)	OVR T2 3N 40-440 P(TS)U	L-GND 420 Veff Max L-L 840 Veff Max	L-GND 1500 V Max L-L 3000 V Max	1 / 10 kA
PSD1-M_P02 0	Cooper Bussmann LLC (E340782)	BSPM 4480 WY NGR	L-GND 660 Veff Max L-L 770 Veff Max	L-GND 2500 V Max L-L 2500 V Max	1 / 20 kA
	DEHN + SOEHNE GmbH + Co. KG. (E319777)	904 346			

Ground rail not sufficient

For CSA approval, earth rail must be replaced by a direct earth connection.



Risk of Electric Shock, wait at least 10 minutes before removing cover.

Removing the earth rail (4) (Right):

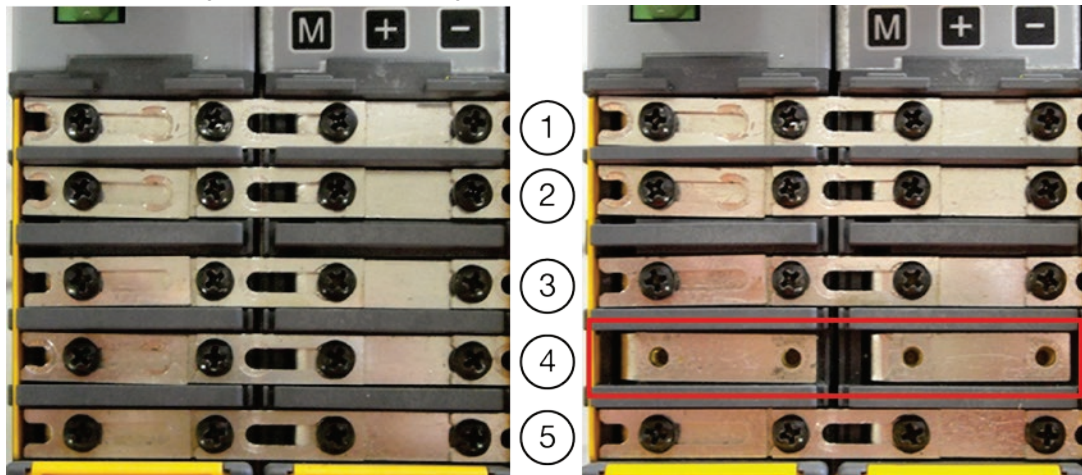

- 1 24 VDC
- 2 GND 24 VDC
- 3 DC power supply bus -
- 4 Protective earth
- 5 DC power supply bus +



Connecting protective earth

Connect protective earth via a copper wire of minimum 10 mm² by means of the provided screws at the bottom of the PSD1M (axis controller) and of the mains module PSD1-M_P:





2.10.5. Conditions of utilization for the cUL certification of PSD1-S

In diesem Kapitel finden Sie

• UL certification.....	24
• Installations- & Environmental Characteristics PSD1-S.....	24
• Tightening torque of the wiring terminals	25
• Auxiliary connection – electrical ratings	26
• Data of integrated dynamic brake unit	26
• In- / Output Ratings	26

2.10.5.1 UL certification

Category	Specifications
Certified	E-File_No.: E235342 The UL certification is only valid if the type plate of the device shows the "UL" -sign. 
PSD1-S:	UL61800-5-1 1st Edition, issued June, 8th, 2012 C22.2 No.274-13, 1st Edition, issued March, 2013

2.10.5.2 Installations- & Environmental Characteristics PSD1-S

CAUTION

Risk of Electric Shock, wait at least 3 minutes with PSD1-S and 10 minutes with PSD1-M before removing cover

- Use in Pollution degree 2 Environment.
- Maximum Surrounding Air Temperature 40 °C.
- The devices must be appropriately protected (e.g. by a switching cabinet). - Open type equipment.
- Use 60/75°C wires only
Use Copper Conductors Only
Do only use the Parker cables available under **Accessories** (see page 82) or assemble the cables according to the specified regulations.
- Control voltage supply (24 VDC) only permissible with "class 2" power supply.
- Grounding Terminals - the screw terminals are suitable for Field Wiring Connection only when the wire is provided with Eyelet Tube Terminal.
- Overvoltage category III.
- Short circuit ratings SCCR = 5000 Arms
- The drive modules are equipped with a current limit. Values for maximum device current and maximum motor current can be set via PSD ServoManager (Chapter resp. Menu Limit values & Motor Characteristics).
- Integral motor overload protection is not available.
- The drive does not incorporate internal overload protection for the motor load and this overload protection shall be provided in the end use applications.
- Motor over temperature sensing is not provided by the drive
- Integral solid state short circuit protection does not provide branch circuit protection. Branch circuit protection must be provided in accordance with the Manufacturer Instructions, National Electrical Code and any additional local codes





- Suitable for use on a circuit capable of delivering not more than 5000 rms Symmetrical Amperes, 240 Vac maximum. When protected by Listed – Cartridge Fuses, Non-Renewable (JDDZ), Time-Delay Class-CC Fuses, rated 600 Vac, 3 A or 8A (for model No. PSD1SW1200) / 6 A or 12A (for model No. PSD1SW1300). See table below for the manufacturers, model number and electrical ratings.

External Branch Circuit Protection

Device	Spezification			
	Time-Delay "Class-CC" Fuses Listed – Cartridge Fuses, Non-Renewable manufactured by Cooper Bussmann LLC (E4273) (200 kARMS Symmetrical A.I.C.)			
	Model No.	Current [Arms]	Voltage [VAC]	Quantity Phase
PSD1-S_1200	LP-CC-8	8	600	1 phase
	LP-CC-3	3	600	3 phases
PSD1-S_1300	LP-CC-12	12	600	1 phase
	LP-CC-6	6	600	3 phases

Alternate External Branch Circuit Protection

Device	Spezification			
	Time-Delay "Class-CC" Fuses Listed – Cartridge Fuses, Non-Renewable manufactured by Mersen USA Newburyport-MA LLC (E2137) (200 kARMS Symmetrical A.I.C.)			
	Model No.	Current [Arms]	Voltage [VAC]	Quantity Phase
PSD1-S_1200	ATDR8	8	600	1 phase
	ATDR3	3	600	3 phases
PSD1-S_1300	ATDR12	12	600	1 phase
	ATDR6	6	600	3 phases

For use in Canada:

- External Surge Protection devices (required in the end use instalation) - According to the Canadian Standard C22.2-No.274-13.
- R/C Surge-Protective Device (VZCA2/8) and CSA-Certified transient surge suppression shall be installed on the line side of this equipment and shall be rated minimum 240 V (phase to ground), suitable for "Overvoltage Category III", and shall provide protection for a rated Impulse withstand Voltage peak of 4 kV.

2.10.5.3 Tightening torque of the wiring terminals

Connector	Torque	mm ²	AWG
X17 Digital I/Os	Push-In	0,2 ... 1,5*	24-16
X51 DSL® feedback / motor brake	Push-In	0,2 ... 1,5*	24-16
X52 Motor	Push-In	0,2 ... 2,5**	26-12
X63 Mains supply / DC power	Push-In	0,2 ... 2,5**	26-12

* max 0,75mm² ferrule with plastic sleeve

** max 1,5mm² ferrule with plastic sleeve





2.10.5.4 Auxiliary connection – electrical ratings

DC Bus Input / Output – X63

400 VDC / D.C. / 7 A

Auxiliary Input Supply – X17

Control Supply - Max 24 VDC \pm 10% / max 0.5 ADC

Signal I/O's Ports (PELV circuit) – X51

Signal I/O's / Communication Ports - max 24 VDC / max 100 mA

2.10.5.5 Data of integrated dynamic brake unit

Internal DBU Ratings

Servo-Drive Model Nos.	Max Current - Amps		Max Duty Cycle - per cent	Internal D.B.U. Resistor Ratings (Ohm)
	Peak	rms		
PSD1SW1200 PSD1SW1300	7.84 A	0.1 A	1.27 % (@60s)	51 Ω (40 W)

External DBU Ratings

Servo-Drive Model Nos.	Max Current - Amps		Max Duty Cycle - per cent	Min Resistance D.B.U. Resistor (Ohm)
	Peak	rms		
PSD1SW1200	7.84 A	0.15 A	1.91 % (@60s)	51 Ω (60 W)
PSD1SW1300	7.84 A	0.45 A	5.73 % (@60s)	51 Ω (180 W)

2.10.5.6 In- / Output Ratings

Input Ratings

Servo-Drive Model Nos.	Input Voltage V AC	Frequency Phase	Maximum Input Current A rms
PSD1SW1200	3AC230 VAC \pm 10 %	50/60 Hz	1.7
PSD1SW1300			4.2
PSD1SW1200	1AC230 VAC \pm 10 %	50/60 Hz	6.8
PSD1SW1300			11.0

Output ratings

Device	Range of Output Voltage VAC	Range of Frequency / Phase	Output Current		Max. Continuous Output Power kW
			Nominal A rms (Continuous)	Maximum A rms (Duty Cycle)*	
PSD1SW1200	0-230 VAC	0-400 Hz	2	6	0.64
PSD1SW1300		/ Three-Phase	5	15	1.1

Note:

* "Duty Cycle": 20% @10 s (ON=2.0 s - OFF=8.0 s)





2.10.6. Current on the mains PE (leakage current)

WARNING

This product can cause a direct current in the protective lead. If a residual current device (RCD) is used for protection in the event of direct or indirect contact, only a type B (all current sensitive) RCD is permitted on the current supply side of this product. Otherwise, a different protective measure must be taken, such as separation from the environment by doubled or enforced insulation or separation from the mains power supply by means of a transformer. Respect the supplier's instructions.

Mains filters do have high leakage currents due to their internal capacity. An internal mains filter is usually integrated into the servo controllers. Additional discharge currents are caused by the capacities of the motor cable and the motor winding. Due to the high clock frequency of the power output stage, the leakage currents do have high-frequency components. Please check if the FI protection switch is suitable for the individual application.

If an external mains filter is used, an additional leakage current will be produced. The figure of the leakage current depends on the following factors:

- Length and properties of the motor cable
- Switching frequency
- Operation with or without external mains filter
- Motor cable with or without shield network
- Motor housing grounding (how and where)

Remark:

- The leakage current is important with respect to the handling and usage safety of the device.
- A pulsing leakage current occurs if the supply voltage is switched on.

Please note:

The device must be operated with effective grounding connection, which must comply with the local regulations for high leakage currents (>3.5 mA).

Due to the high leakage currents it is not advisable to operate the servo drive with an earth leakage circuit breaker.

2.10.7. Supply networks

This product is designed for fixed connection to TN networks (TN-C, TN-C-S or TN-S). Please note that the line-earth voltage may not exceed 300VAC.

- When grounding the neutral conductor, mains voltages of up to 480VAC are permitted.
- When grounding an external conductor (delta mains, two-phase mains), mains voltages (external conductor voltages) of up to 240VAC are permitted.

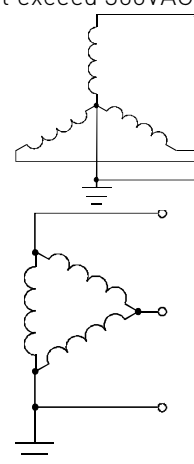

Devices which are to be connected to an IT network must be provided with a separating transformer. Then the devices are operated locally as in a TN network. The secondary sided center of the separating transformer must be grounded and connected to the PE connector of the device.





2.11 Before commissioning the drive, please observe the following:

- Read the safety instructions.
- Make sure that all local electrical regulations are adhered to.
- Inspect the device for any damages.
- Inspect the device within the drive and system for loose ends, blends, grinding- or drilling chips, etc.
- Check all external power circuits of the system: Power supply, control, motor and ground connections.
- Make sure no damages or injuries may occur by a rotating motor. Uncouple the load from the motor shaft.
- Check the condition of the motor thermistor- and brake resistance connections. Make sure that all external set speeds are zero.
- Make sure nobody works with another part of the system which may affect switch-on.
- Make sure that switch-on does not negatively influence other devices.
- Verify if the motor connections are correctly wired.
- Ensure that the STO function is not activated.





3. PSD: PSD -Parker Servo Drive - Overview

Description

The PSD1 is Parker Servo Drive family, available with different power rating from 2 to 30A and form factors.

Today the offering contains:

The PSD1-S is a standalone drive which can be connected directly to the main supply.

The PSD1-M is a multi-axis servo system where each axis module can supply up to three servo motors. The base configuration consists of a common DC bus supply and multiples PSD1-M modules, connected through DC bus bars. The modules are available as one, two or three axis versions. This makes the system highly flexible.

PSD1-M servo system is particularly suitable for all centralised automation systems, such as those found in many packaging machines, where large numbers of drives are often required offering significant advantages.

- Packaging machines
- Material forming machines
- Handling machines
- General automation

Common Features

- Hiperface DSL feedback ®
Reduced cabling; only one cable connection between drive & motor
- EtherCAT - Real time communication as standard
- Quick and simple wiring
- Removable SD card
- Same software functionalities for standalone drive and multi-axis servo system

PSD1-S unique features

- Single or three phases power supply
- Compact housing
- Particularly suitable for small machines

PSD1-M unique features

- The most compact multi-axis servo system on the market
- One, two or three axis versions combined in one housing
- Common DC bus connection for energy exchange between drives



Technical characteristics - Overview

Standalone axis PSD1 S	Continuous current [A _{rms}]	Peak current A (≤ 2 s)
PSD1 SW1200	2	6
PSD1 SW1300	5	15

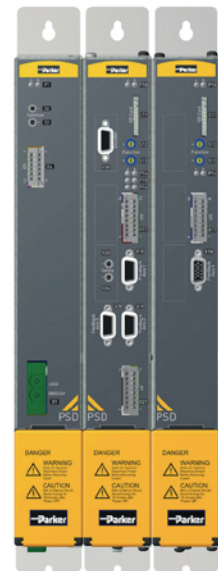

Multi axis PSD1 M	Continuous current [A _{rms}]	Peak current A (≤ 2 s)
PSD1 MW1300	5	10
PSD1 MW1400	8	16
PSD1 MW1600	15	30
PSD1 MW1800	30	60
PSD1 MW2220	2 + 2	4 + 4
PSD1 MW2330	5 + 5	10 + 10
PSD1 MW2440	8 + 8	16 + 16
PSD1 MW2630	15 + 5	30 + 10
PSD1 MW3222	2 + 2 + 2	4 + 4 + 4
PSD1 MW3433	8 + 5 + 5	16 + 10 + 10

(additional module on request)





4. Installation of the individual drive PSD1-S

In this chapter you can read about:

• Before commissioning the drive, please observe the following:.....	30
• Mounting and dimensions.....	30
• Connector overview PSD1-S.....	31
• P14: Status LED (PSD1-S).....	34
• X17: Digital Inputs / outputs (PSD1-S).....	35
• Wiring of the digital inputs and outputs	36
• X63: AC Mains Supply, DC voltage supply & Connection of braking resistor (PSD1-S)	36
• X52: Motor Connection (PSD1-S).....	38
• X51: Motor holding brake and HIPERFACE DSL® - Connection	38
• X60: PC-/Diagnostic interface.....	39
• Communication interfaces	39

4.1 Before commissioning the drive, please observe the following:

CAUTION: Risk of electric shock



Caution - Risk of electric shock!

Before wiring or loosening electrical connections please observe the following:



- Risk of electric shock, disconnect power before removing cover resp. disconnect the devices from the mains supply.

- **Caution!** Dangerous electrical voltage even after turning off the intermediate capacitors:

Up to 3 minutes with PSD1-S and 10 minutes with PSD1-M after switching off mains supply, dangerous voltages may still be present.

Please check that no voltages are present (<50 V) at the output terminals DC+ and DC- of PSD1-S: X63/3 & X63/5 and with PSD1-M: Bus HV DC - 3 & 5. rail.



Only qualified electrician may commission the drive.
Accident prevention measures must be observed.



Please make sure that no small parts (screws, cable remnants, ...) enter the devices.

4.2 Mounting and dimensions



Ventilation:

- During operation, the device radiates heat (heat dissipation). Please provide for a sufficient mounting distance below and above the device in order to ensure free circulation of the cooling air.
- Please do also respect the recommended distances of other devices.
- Make sure that the mounting plate is not exhibited to other temperature influences than that of the devices mounted on this very plate.
- The devices must be mounted vertically on a level surface. Make sure that all devices are sufficiently fixed.





4.2.1. Mounting and dimensions PSD1-S

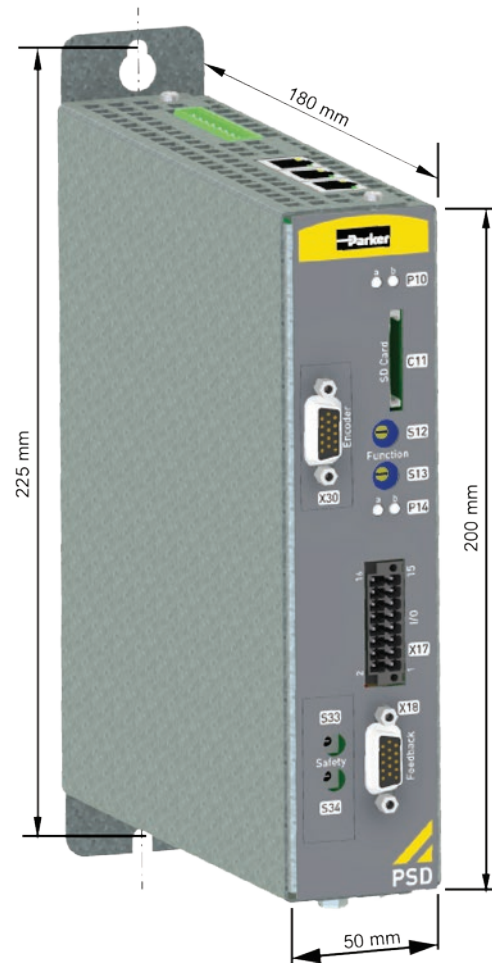

Mounting:

2 socket head screws M6

Lateral distance of fixing of mounting holes: 50.5 mm

Mounting spacing at the top and below: At least 100mm



Please check regularly the firmness of the screw connection!





4.3 Connector overview PSD1-S

In diesem Kapitel finden Sie

- Front view (PSD1-S)..... 32
- View from below (PSD1-S)..... 33
- View from above (PSD1-S)..... 33

4.3.1. Front view (PSD1-S)

CAUTION: Risk of electric shock



Caution - Risk of electric shock!

Before wiring or loosening electrical connections please observe the following:



- Risk of electric shock, disconnect power before removing cover resp. disconnect the devices from the mains supply.

- **Caution!** Dangerous electrical voltage even after turning off the intermediate capacitors:

Up to 3 minutes with PSD1-S and 10 minutes with PSD1-M after switching off mains supply, dangerous voltages may still be present.

Please check that no voltages are present (<50 V) at the output terminals DC+ and DC- of PSD1-S: X63/3 & X63/5 and with PSD1-M: Bus HV DC - 3 & 5. rail.

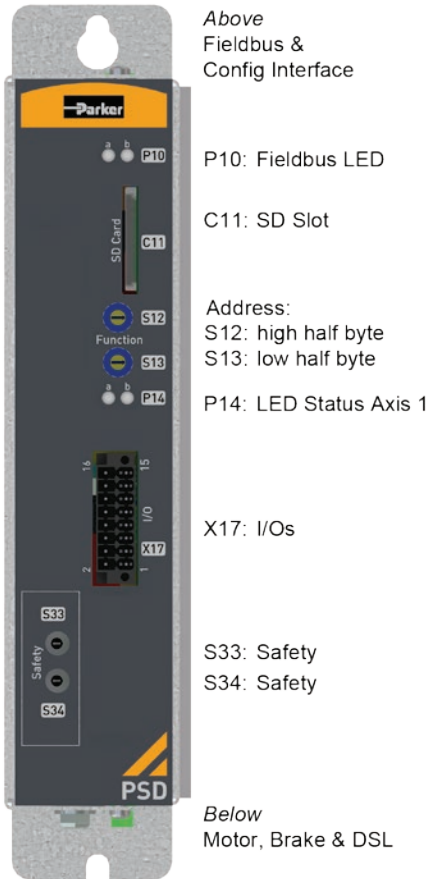

View from above (see page 33)	
P10	Status LEDs for the fieldbus
C11	Slot for SD card (SD card not included in delivery)
S12	Device address higher value half-byte (accept with power ON)
S13	Device address low value half-byte (accept with power ON)
P14 (see page 34)	Status LED device
X17 (see page 35)	Digital inputs/outputs
S33	For safety option
S34	For safety option
View from below (see page 33)	





4.3.2. View from below (PSD1-S)

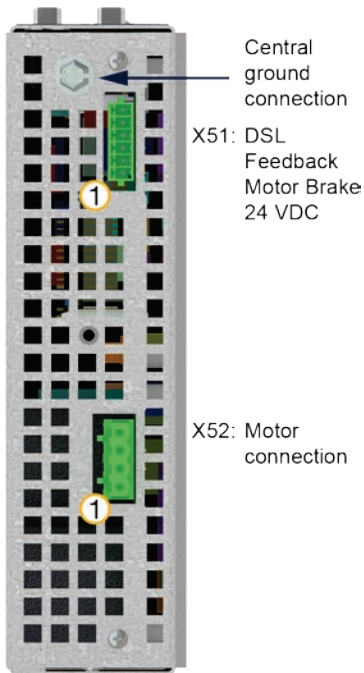

View from above (see page 33)	
X52 (see page 38)	Connection of Motor
X51 (see page 38)	To motor <ul style="list-style-type: none"> • HIPERFACE DSL® Motor feedback • Motor holding brake 24 VDC supply
Central ground connection	Connect ground via ring cable lug with a 10 mm ² copper cable to central ground
Front view (see page 32)	

4.3.3. View from above (PSD1-S)

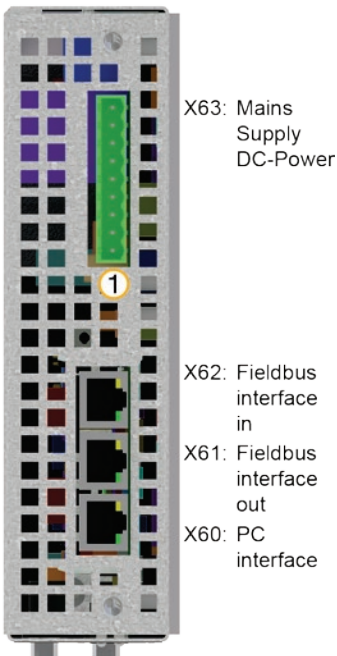

Front view (see page 32)	
X60 (see page 39)	PC Interface to configure and program servo axes
X61 (see page 39)	Fieldbus Interface output
X62 (see page 39)	Fieldbus Interface input
X63 (see page 36)	Terminals <ul style="list-style-type: none"> • AC Mains Supply • DC high voltage supply • Connection of braking resistor or bridge to activate the internal braking resistor
View from below (see page 33)	





4.4 P14: Status LED (PSD1-S)

Status No.	Status of axis	Left LED a (green) (Ready)	Right LED b (red) (Error)
0	No voltage	off	off
1	Booting of axis, firmware is missing	alternate quick flashing (LED1 green, LED2 red)	
2	Axis not ready: <ul style="list-style-type: none"> • Booting of axis • No feedback detected. • IEC61131-3 program not compatible with firmware. • no IEC61131-3 program • Hall signals invalid. 	off	flashes quickly
3	Axis de-energized	flashes slowly	off
4	Axis energized; commutation calibration running	flashes quickly	off
5	Axis energized	on	off
6	Axis in error state / error present / axis energized (error reaction 1)	on	flashes quickly
7	Axis in error state / error present / axis de-energized (error reaction 2)	off	on
8	Axis faulty: Please contact us	on	on
9	STO Active	off	flashes slowly
10	-	flashes quickly	flashes quickly
11	SD card detected	alternate quick flashing (LED1 green, LED2 red)	
12	SD card not detected	alternate quick flashing (LED1 red, LED2 red)	
13	Axis de-energized	off	Single flash
14	Axis energized	on	Single flash
15	Axis de-energized HEDA3 slave not ready	off	Double flash
16	Axis energized HEDA3 Slave not ready	on	Double flash
17	Axis de-energized HEDA3 Master not ready	off	Triple flash
18	Axis energized HEDA3 Master not ready	on	Triple flash
19	Axis de-energized	off	Jitter
20	Axis energized	on	Jitter

Error response 1: Ramping down with slow ramp; then deactivate control loops.

Error response 2: Ramping down with "Stop" ramp, then deactivation of the control loops.

For the meaning of individuals errors please go to Error list.

Single flash

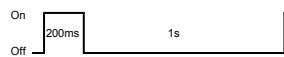

Double flash

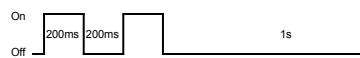

Triple flash



Caution - Risk of electric shock!

High voltage supply may be present even with missing voltage supply (both LEDs off)!





4.5 X17: Digital Inputs / outputs (PSD1-S)

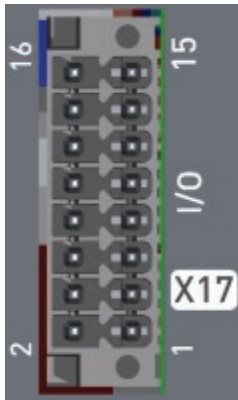

Pin X17	Input / Output	
1	Input	+24 VDC Devices - Control voltage
2	Input	GND24V
3	Input	+24 VDC for digital outputs
4	I0	Input 0
5	I1	Input 1
6	I2	Input 2
7	I3	Input 3
8	GND24V	
9	O0	Output 0
10	GND24V	
11	A1	Output 1
12	STOA/	STO Channel A Input
13	factory use	
14	STOGND	STO Ground
15	factory use	
16	STOB/	STO Channel B input

Loading of the outputs: Maximum 200 mA

In case of overload / over-temperature the output is deactivated and reactivated automatically after cooling.

All inputs and outputs do have 24 V level.

Input level:

"0" (low) = Rated Input Voltage \leq 12.5 V

"1" (high) = Rated Input Voltage \geq 13.5 V

The digital outputs are free for writing via object "0x2079.0x01: DemandValue" via fieldbus.

The status of digital inputs can be read via object "0x2070.0x00:

DigitalDriveInputs".DigitalDriveInputs" gelesen basis.

4.5.1. Control Voltage 24 VDC PSD1-S

Category	Specifications
Voltage operating range	21 - 27 VDC
Ripple	0.5 V _{ss}
Requirement according to safe extra low voltage (SELV)	yes (class 2 mains module)
Electric current drain	0.5 A + Output current of digital output currents (fed via connectors X17/2, 3) + Output current of motor brakes (fed via connectors X51/1 & 2)) + Current requirements of optional boards





4.6 Wiring of the digital inputs and outputs

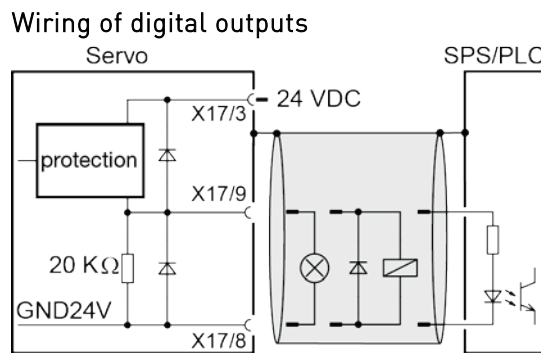
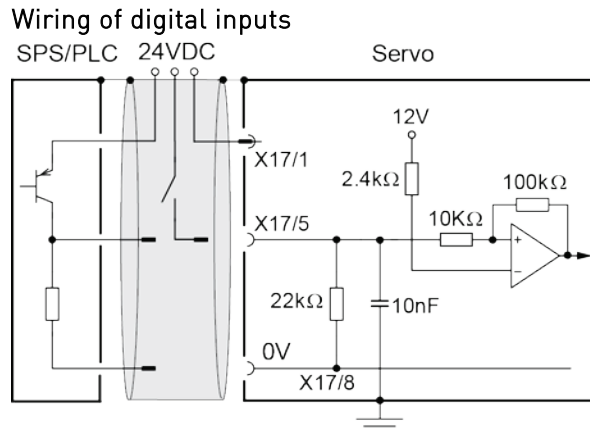

4.7 X63: AC Mains Supply, DC voltage supply & Connection of braking resistor (PSD1-S)

Pin	Designation	Description	
1	Rin	Internal Brake Resistor *	
2	-R	Output for brake resistor connection -	
3	+R	Output for brake resistor connection +	
4	DC+	Power direct current +	
5	DC-	Power direct current -	
6	L3	Phase 3 (mains supply)	factory use
7	L2	Phase 2 (Mains Supply)	N (Single Phase)
8	L1	Phase 1 (Mains Supply)	L (Single Phase)
9	PE	Earth conductor	

* The internal brake resistance is connected via bridge X63/1 and X63/2:

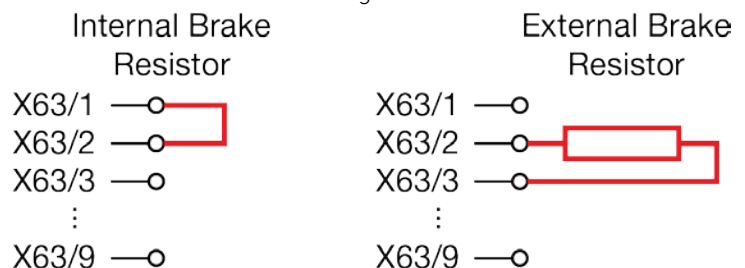

⚠ WARNING

Device protection

By cyclically switching on and off the power voltage, the input current limitation can be overloaded, which may cause damage to the device.

Wait at least one minute between two switching on processes!



**NOTICE****Please note!**

If neither a braking resistor nor a bridge are connected, the intermediate circuit voltage is 0.

4.7.1. Mains connection PSD1-S

Category	Specifications	
PSD1-S	PSD1-S_1200	PSD1-S_1300
Mains voltage	3 phases 3* 230 VAC ±10% 30 ... 253 VAC / 50-60 Hz or Single Phase 230 VAC ±10% 30 ... 253 VAC / 50-60 Hz	
Input Current	(1AC230V): 6.8 Arms 3AC230V: 1.7 Arms	(1AC230V): 11 Arms 3AC230V: 4.2 Arms
Maximum fuse per device*	Single phase: 8 A Three phases: 3 A Fuse Class: gS (gRL), Time-delay	Single phase: 12 A Three phases: 6 A Fuse Class: gS (gRL), Time-delay
Earth leakage current	Current on the mains PE (see page 27) (>3,5 mA)	
Supply networks	Possible supply networks (see page 27): TN	

* Circuit breakers for operation according to CE.
Circuit breakers for UL und CSA see **UL Chapter** (see page 20, see page 24).

4.7.2. Braking operation PSD1-S

Category	Specifications	
Controller type	PSD1-S_1200 (2 A)	PSD1-S_1300 (5 A)
Capacity/ storable energy	760 µF / 15 Ws	1140 µF / 23 Ws
Minimum braking resistance	51 Ω	51 Ω
Maximum continuous current	7.85 A	7.85 A

External ballast resistors from Parker (see page 92).

Data of the integrated dynamic brake module PSD1-S

Category	Specifications			
Mains module	Maximum current		Max. Duty Cycle	Minimum resistance value
	Peak	Duration		
PSD1-SW1200	7.84 A	0.1 A	1.27% @ 60 s	51 Ω (40W)
PSD1-SW1300				





4.8 X52: Motor Connection (PSD1-S)

Pin	Designation	Motor cable lead designation*		
1	U	U / L1	1	U1
2	V	V / L2	2	U2
3	W	W / L3	3	U3
4	FE	YE / GN		

* Depending on cable type.

FE: Functional ground

Shielding connection of the motor cable

The cable must be fully-screened and connected to the device housing. Use the cable clamps/shield connecting terminals furnished with the device.

The shield of the cable must also be connected with the motor housing. The fixing (via plug or screw in the terminal box) depends on the motor type.

4.8.1. Output data PSD1-S 1/3*230 VAC

Category	Specifications	
	PSD1-S_1200 (2 A)	PSD1-S_1300 (5 A)
Device type		
Output voltage	3 x 0 ... 230 V ±10 %	
Output nominal current (In)	2 A _{rms}	5 A _{rms}
Pulse current for 2 s	6 A _{rms}	15 A _{rms}
Power at continuous operation	0.64kW (3-phases mains supply) 0.64 kW (1-phase mains supply)	1.1 kW (3-phases mains supply) 1.1 kW (1-phase mains supply)
Switching frequency of the motor current	8 kHz	8 kHz
Heat dissipation for In	13 W	35 W

4.9 X51: Motor holding brake and HIPERFACE DSL® - Connection

Pin	Designation	Description
1	DC 24 V	Input Power supply brake 24 VDC
2	GND24V	Input Power supply of brake GND24V
3	Br +	Output of motor holding brake + (max 1.0 A)
4	Br -	Output of motor holding brake - (connected with GND24V)
5	DSL+	Feedback
6	DSL-	Feedback

Operation only with Parker HIPERFACE DSL® cable (see page 84)!
Please contact us if you want to use a different cable.





4.10 X60: PC-/Diagnostic interface

Wiring with Ethernet Crossover cable Cat5e; for this, we offer our **CBD000C0-T00-T0** (see page 95) interface cable.

Standard Ethernet Address of the PSD:192.168.10.x

The final position (x) is set via the address adder S12 (higher value byte) & S13 (low value byte) and accepted by Power On.

Address setting

Settings:

S12: Device address higher value half-byte (accept with power ON)

S13: Device address low value half-byte (accept with power ON)

Example: S12=2, S13=1

Address= 0x21: S12*16 + S13 = 33

Addresses 0 and 241 ... 255 are not possible.

Connection is configured in PSD ServoManager.

4.11 Communication interfaces

4.11.1. X61, X62 Ethernet Connection

RJ45-Socket: Assignment

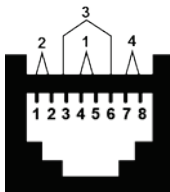

Pin	Wire pair No.	RJ45 (X61)	RJ45 (X62)
		out	in
1	2	Tx +	Tx +
2	2	Tx -	Tx -
3	3	Rx +	Rx +
4	1	-	factory use
5	1	-	factory use
6	3	Rx -	Rx -
7	4	-	factory use
8	4	-	factory use

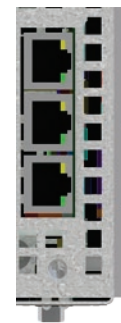

X62: Fieldbus interface in
X61: Fieldbus interface out
X60: PC interface

Wiring with Ethernet Crossover cable Cat5e (from X61 to X62 of the next device without termination); for this, we offer our **CBD000C0-T00-T0** (see page 95) interface cable.





5. Installation of the multi-axis system PSD1-M

The PSD1 multi-axis system consist of a power module (PSD1-M_P) und the axis modules (PSD1-M_x).

The axis module drives 1 to 3 motors, depending on the type (x=1, 2 or 3).

Please observe that the operation of the axis modules is only permitted via the Parker Power Module PSD1-M_P.



In this chapter you can read about:

- Before commissioning the drive, please observe the following:..... 41
- Mounting and dimensions..... 41
- Connector overview PSD1-M..... 43
- P14 ... P16: Status LEDs of the individual axes (PSD1-M)..... 48
- X17: Digital Inputs / outputs Axis 1 & 3 (PSD1-M)..... 49
- X21: Digital Inputs / outputs Axis 2 & 3 (PSD1-M)..... 50
- X18 - X19 X20 feedback connector: Assignment with incremental encoder 51
- Wiring of the digital inputs and outputs 51
- Motor connection / Output data..... 52
- X46: Connection of motor brake (PSD1-M)..... 54
- X44: Connection of motor brake (PSD1M_1800) 54
- X48: HIPERFACE DSL® & Motor temperature sensor (PSD1-M)..... 54
- Mains module PSD1-M_P 54
- X60: PC-/Diagnostic interface..... 65
- Communication interfaces 65





5.1 Before commissioning the drive, please observe the following:

CAUTION: Risk of electric shock



Caution - Risk of electric shock!

Before wiring or loosening electrical connections please observe the following:



- Risk of electric shock, disconnect power before removing cover resp. disconnect the devices from the mains supply.

- **Caution!** Dangerous electrical voltage even after turning off the intermediate capacitors:

Up to 3 minutes with PSD1-S and 10 minutes with PSD1-M after switching off mains supply, dangerous voltages may still be present.

Please check that no voltages are present (<50 V) at the output terminals DC+ and DC- of PSD1-S: X63/3 & X63/5 and with PSD1-M: Bus HV DC - 3 & 5. rail.



Only qualified electrician may commission the drive.
Accident prevention measures must be observed.



Please make sure that no small parts (screws, cable remnants, ...) enter the devices.

5.2 Mounting and dimensions



Ventilation:

- During operation, the device radiates heat (heat dissipation). Please provide for a sufficient mounting distance below and above the device in order to ensure free circulation of the cooling air.
- Please do also respect the recommended distances of other devices.
- Make sure that the mounting plate is not exhibited to other temperature influences than that of the devices mounted on this very plate.
- The devices must be mounted vertically on a level surface. Make sure that all devices are sufficiently fixed.





5.2.1. Mounting and dimensions PSD1-M size 1

The devices are force-ventilated via a ventilator fan fixed to the lower part of the heat dissipator!

Mounting spacing: At the top and below: at least 100mm

Information on

- PSD1-M Size 1
- Multi axes servo drives and
 - Mains Module PSD1-M_P010

Mounting:

- 2 socket head screws M6
- Lateral distance of fixing of mounting holes: 50.5 mm
- Mounting spacing at the top and below: At least 100mm



Please check regularly the firmness of the screw connection!

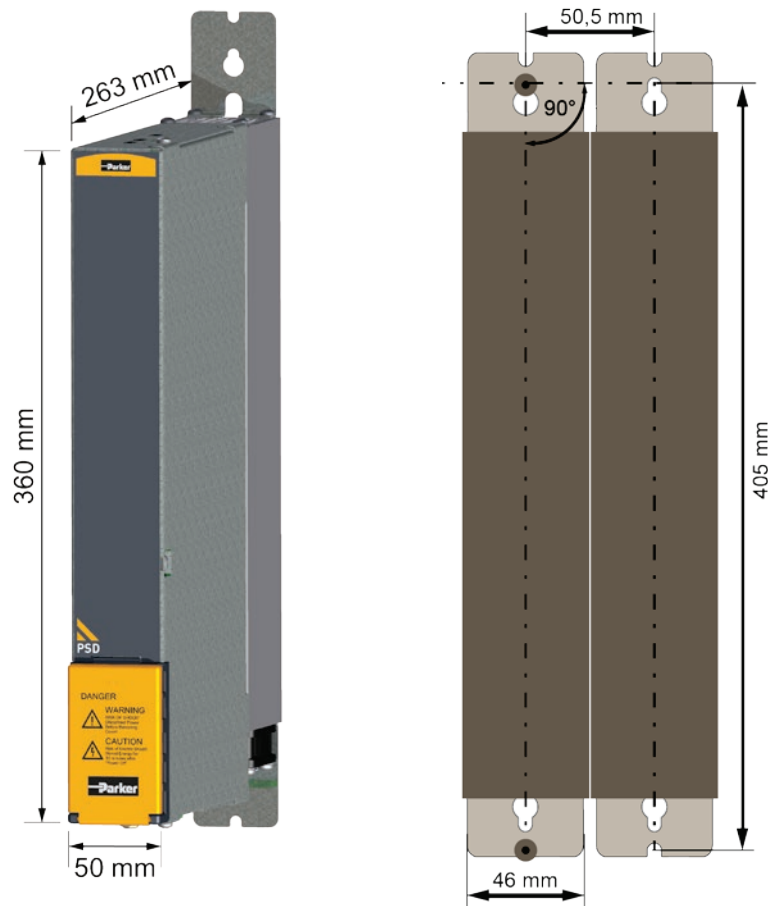

Tolerances: DIN ISO 2768-f





5.2.2. Mounting and dimensions PSD1-M size 2

Information on PSD1-M Size 2
Multi axis Servo Drives (30 A) and
Mains Module PSD1-M_P020

Mounting:
4 socket head screws M5

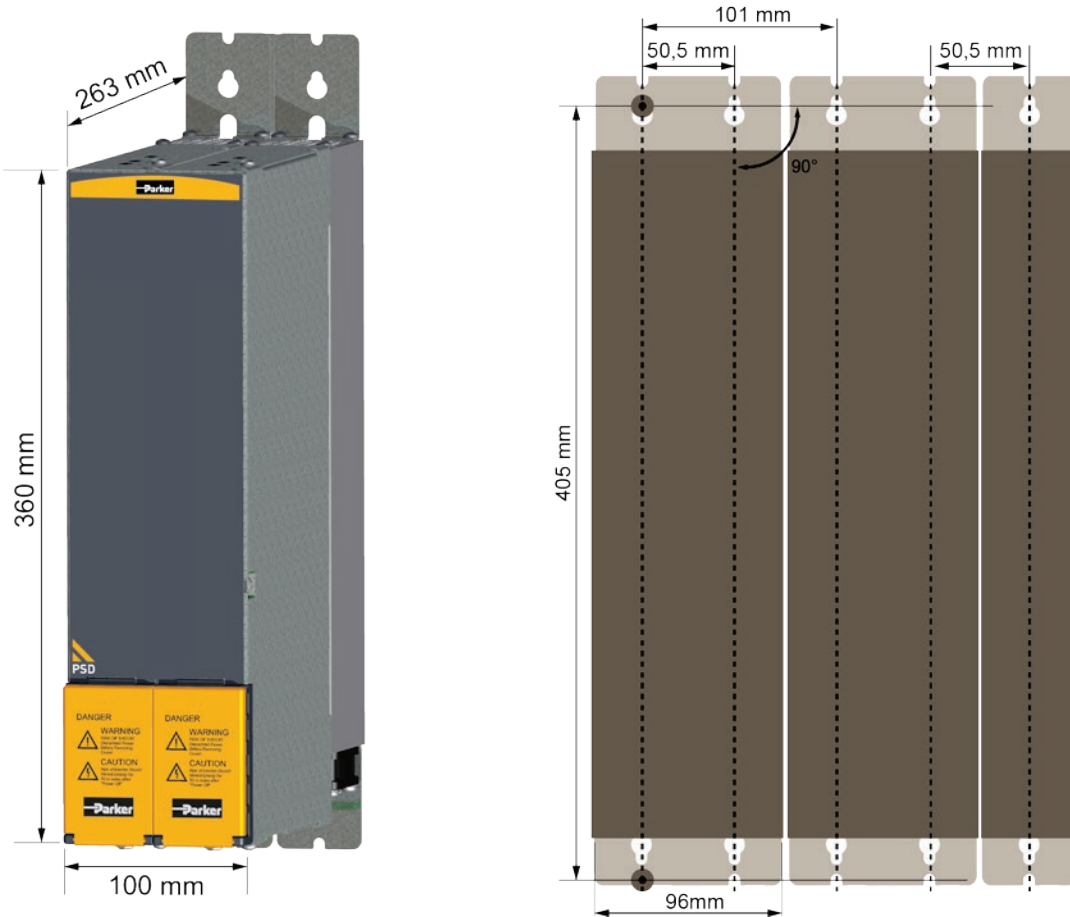

Tolerances: DIN ISO 2768-f





5.3 Connector overview PSD1-M

In diesem Kapitel finden Sie

- Front view (PSD1-S)..... 44
- View from below (PSD1-M) 46
- View from above (PSD1-M) 47

5.3.1. Front view (PSD1-S)

CAUTION: Risk of electric shock



Caution - Risk of electric shock!

Before wiring or loosening electrical connections please observe the following:



- Risk of electric shock, disconnect power before removing cover resp. disconnect the devices from the mains supply.

- **Caution!** Dangerous electrical voltage even after turning off the intermediate capacitors:

Up to 3 minutes with PSD1-S and 10 minutes with PSD1-M after switching off mains supply, dangerous voltages may still be present.

Please check that no voltages are present (<50 V) at the output terminals DC+ and DC- of PSD1-S: X63/3 & X63/5 and with PSD1-M: Bus HV DC - 3 & 5. rail.



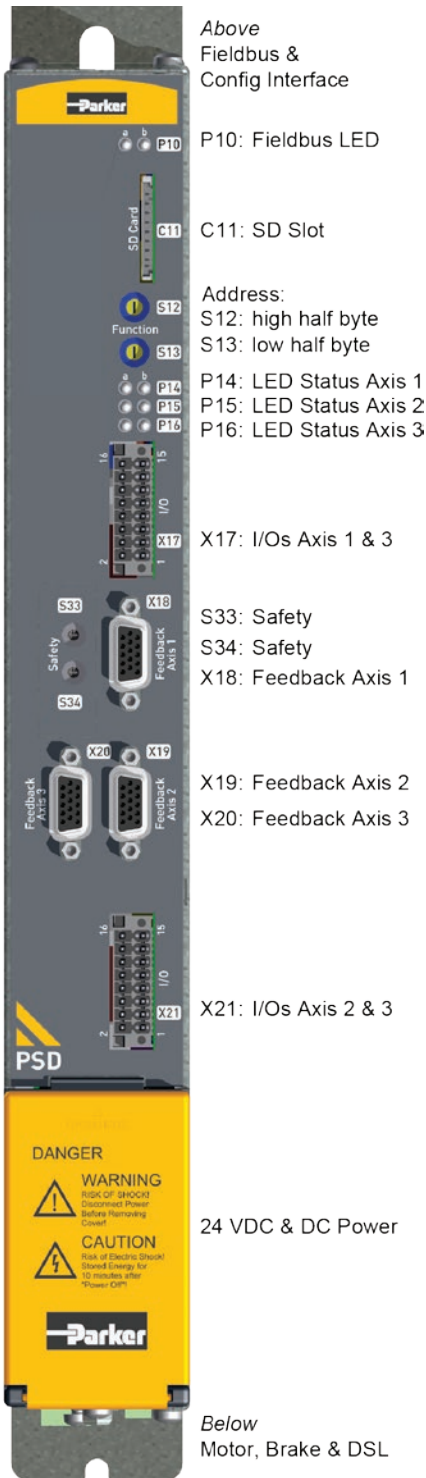

Above
Fieldbus &
Config Interface

P10: Fieldbus LED

C11: SD Slot

Address:
S12: high half byte
S13: low half byte

P14: LED Status Axis 1
P15: LED Status Axis 2
P16: LED Status Axis 3

X17: I/Os Axis 1 & 3

S33: Safety
S34: Safety
X18: Feedback Axis 1

X19: Feedback Axis 2
X20: Feedback Axis 3

X21: I/Os Axis 2 & 3

24 VDC & DC Power

Below
Motor, Brake & DSL

View from above (see page 47)	
P10	Status LEDs for the fieldbus
C11	Slot for SD card (SD card not included in delivery)
S12	Device address higher value half-byte (accept with power ON)
S13	Device address low value half-byte (accept with power ON)
P14 (see page 48)	Status LED axis 1
P15 (see page 48)	Status LED axis 2
P16 (see page 48)	Status LED axis 3
X17 (see page 49)	Digital inputs/outputs axis 1 & 3
X18 (see page 51)	Feedback device male connector axis 1
X19 (see page 51)	Feedback device male connector axis 2
X20 (see page 51)	Feedback device male connector axis 3
S33	For safety option
S34	For safety option
X21 (see page 50)	Digital inputs/outputs axis 2 & 3
24 VDC & DC power (see page 59)	Behind the yellow protective covers you can find the rails for the supply voltage connection to the mains module PSD1-M_P . <ul style="list-style-type: none"> • 24 VDC power supply • DC power voltage supply
View from below (see page 46)	



5.3.2. View from below (PSD1-M)

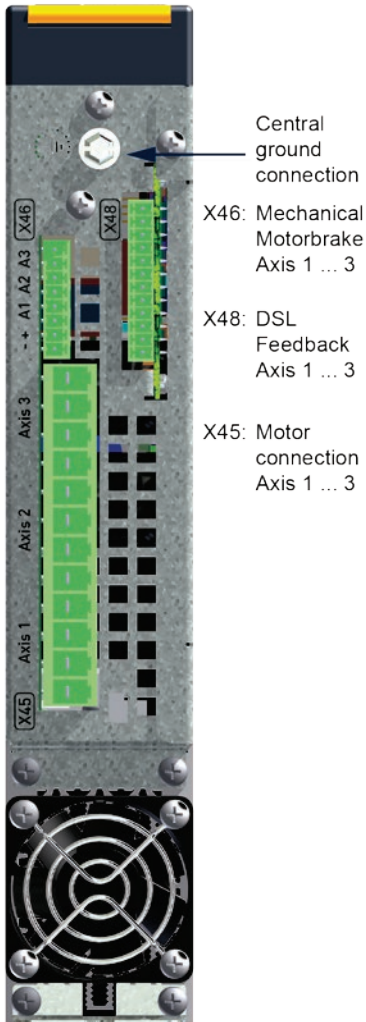

- Central ground connection
- X46: Mechanical Motorbrake Axis 1 ... 3
- X48: DSL Feedback Axis 1 ... 3
- X45: Motor connection Axis 1 ... 3

View from above (see page 47)	
X45 (see page 53) X43 with PSD1M_1800	Motor connections: Axis 1 ... 3 (each device)
X46 (see page 54) X44 with PSD1M_1800	Motor connections: Axis 1 ... 3 (each device)
X48 (see page 54)	Connection of HIPERFACE DSL® Motor - Feedback - Systems and Motor temperature sensor Axis 1 ... 3 (each device)
Central ground connection	Connect ground via ring cable lug with a 10 mm ² copper cable to central ground
Front view (see page 44)	

Tin angle for motor- and feedback sensor cable



Mounting:

- Fix cable on the corresponding tin bar (3)
- Connect plug
- Screw on tin angle

Explanation

- 1 Fixing screw for tin angle (included with delivery)
- 2 Tin angle for cable guiding with earthing screw
- 3 Mounting of cable, flat shield





5.3.3. View from above (PSD1-M)

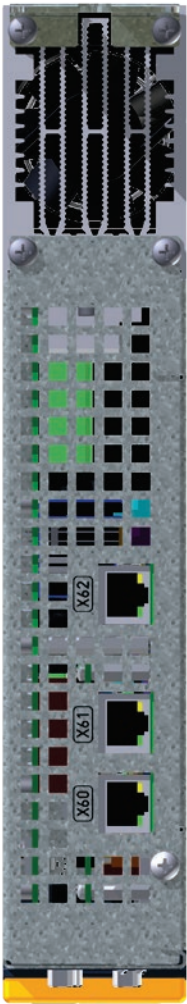

X62: Fieldbus interface in
X61: Fieldbus interface out
X60: PC interface

Front view (see page 44)	
X60	PC Interface to configure and program servo axes
X61 (see page 39)	Fieldbus Interface output
X62 (see page 39)	Fieldbus Interface input
View from below (see page 46)	





5.4 P14 ... P16: Status LEDs of the individual axes (PSD1-M)

- P14: Status Axis 1
- LEDs P15: Status Axis 2
- LEDs P16: Status Axis 3

Status No.	Status of axis	Left LED a (green) (Ready)	Right LED b (red) (Error)
0	No voltage	off	off
1	Booting of axis, firmware is missing	alternate quick flashing (LED1 green, LED2 red)	
2	Axis not ready: <ul style="list-style-type: none"> • Booting of axis • No feedback detected. • IEC61131-3 program not compatible with firmware. • no IEC61131-3 program • Hall signals invalid. 	off	flashes quickly
3	Axis de-energized	flashes slowly	off
4	Axis energized; commutation calibration running	flashes quickly	off
5	Axis energized	on	off
6	Axis in error state / error present / axis energized (error reaction 1)	on	flashes quickly
7	Axis in error state / error present / axis de-energized (error reaction 2)	off	on
8	Axis faulty: Please contact us	on	on
9	STO Active	off	flashes slowly
10	-	flashes quickly	flashes quickly
11	SD card detected	alternate quick flashing (LED1 green, LED2 red)	
12	SD card not detected	alternate quick flashing (LED1 red, LED2 red)	
13	Axis de-energized	off	Single flash
14	Axis energized	on	Single flash
15	Axis de-energized HEDA3 slave not ready	off	Double flash
16	Axis energized HEDA3 Slave not ready	on	Double flash
17	Axis de-energized HEDA3 Master not ready	off	Triple flash
18	Axis energized HEDA3 Master not ready	on	Triple flash
19	Axis de-energized	off	Jitter
20	Axis energized	on	Jitter

Error response 1: Ramping down with slow ramp; then deactivate control loops.

Error response 2: Ramping down with "Stop" ramp, then deactivation of the control loops.

For the meaning of individuals errors please go to Error list.

Single flash

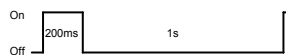

Double flash



Triple flash





Caution - Risk of electric shock!

High voltage supply may be present even with missing voltage supply (both LEDs off)!

5.5 X17: Digital Inputs / outputs Axis 1 & 3 (PSD1-M)

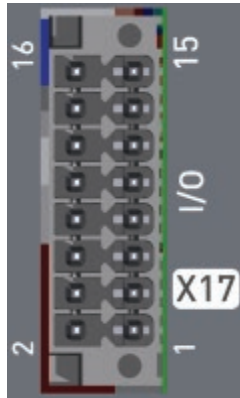

Pin X17	Input / Output	Axis	
1	Output	1 ... 3	+24 VDC
2	Output	1 ... 3	GND24V
3	Input	1 ... 3	+24 VDC Power supply for digital outputs
4	I0_1	1	Input 0 Axis 1
5	I1_1	1	Input 1 Axis 1
6	I2_1	1	Input 2 Axis 1
7	I3_1	1	Input 3 Axis 1
8	GND24V	1 ... 3	
9	O0_1	1	Output 0 Axis 1
10	GND24V	1 ... 3	
11	O1_1	1	Output 1 Axis 1
12	STOA1/	1	STO input A Axis 1
13	I0_3	3	Input 0 Axis 3
14	STOGND1	1	STO Ground
15	I1_3	3	Input 1 Axis 3
16	STOB1/	1	STO input B Axis 1

Loading of the outputs: Maximum 350 mA

In case of overload / over-temperature of an output, all outputs are deactivated and reactivated automatically after cooling.

All inputs and outputs do have 24 V level.

Input level:

"0" (low) = Rated Input Voltage \leq 12.5 V

"1" (high) = Rated Input Voltage \geq 13.5 V

The digital outputs are free for writing via object "0x2079.0x01: DemandValue" via fieldbus.

The status of digital inputs can be read via object "0x2070.0x00:

DigitalDriveInputs".DigitalDriveInputs" gelesen basis.





5.6 X21: Digital Inputs / outputs Axis 2 & 3 (PSD1-M)

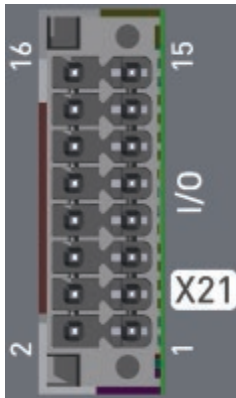

Pin X21	Input / Output	Axis	
1	I2_3	3	Input 2 Axis 3
2	GND24V	1...3	
3	I3_3	3	Input 3 Axis 3
4	I0_2	2	Input 0 Axis 2
5	I1_2	2	Input 1 Axis 2
6	I2_2	2	Input 2 Axis 2
7	I3_2	2	Input 3 Axis 2
8	GND24V	1...3	
9	O0_2	2	Output 0 Axis 2
10	GND24V	1...3	
11	O1_2	2	Output 1 Axis 2
12	STOA2/		STO input A Axis 2/3
13	O0_3	3	Output 0 Axis 3
14	STOGND2	1...3	STO Ground
15	O1_3	3	Output 1 Axis 3
16	STOB2/		STO Input B axis 2/3

Loading of the outputs: Maximum 350 mA

In case of overload / over-temperature of an output, all outputs are deactivated and reactivated automatically after cooling.

All inputs and outputs do have 24 V level.

Input level:

"0" (low) = Rated Input Voltage \leq 12.5 V

"1" (high) = Rated Input Voltage \geq 13.5 V

The digital outputs are free for writing via object "0x2079.0x01: DemandValue" via fieldbus.

The status of digital inputs can be read via object "0x2070.0x00:

DigitalDriveInputs".DigitalDriveInputs" gelesen basis.





5.7 X18 - X19 X20 feedback connector: Assignment with incremental encoder

X18: Axis 1/ single axis devices

X19: Axis 2: not implemented

X20: Axis 3: not implemented

Incremental encoder / analogue HAL sensor with analogue Sin/Cos signals with 1V_{SS}

Pin	Feedback option/ high density/sub D
1	Sense -*
2	Sense +*
3	factory use
4	Vcc (+5V) max. 350 mA load
5	+3,3V (for temperature sensor)
6	factory use
7	SIN-, A- (Encoder) or analog Hall sensor
8	SIN+, A+, (Encoder) or analog Hall sensor
9	factory use
10	Tmot*
11	COS-, B- (Encoder) or analog Hall sensor
12	COS+ / B+ (Encoder) or analogue Hall sensor
13	N+, Z+, Ref + (encoder reference mark or index pulse +)
14	N+, Z+, Ref + (encoder reference mark or index pulse -)
15	GND (Vcc)

*+5V (Pin 4) is measured and controlled directly at the end of the line via Sense+ and Sense-.

Maximum cable length: 100 m

Category	Specifications
Sinus-Cosinus Encoder / analogue Hall sensor (see page 51) *	<ul style="list-style-type: none"> Linear or rotary Sin/Cos signal: max. 5 V_{SS}; typical 1 V_{SS}; 90° offset Max. 200 kHz

* in the first stage only for PSD1MV1...: Multi axes device with one powerstage.

5.8 Wiring of the digital inputs and outputs

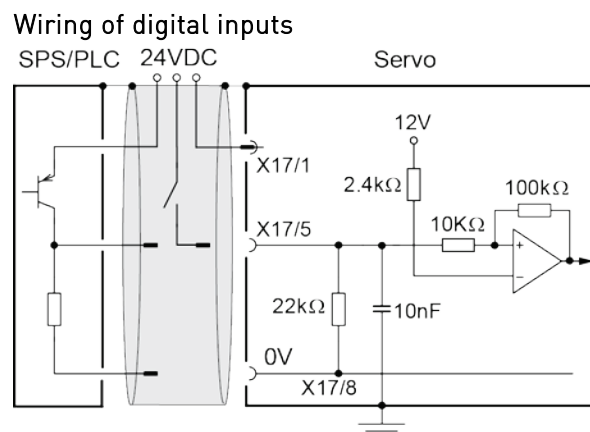

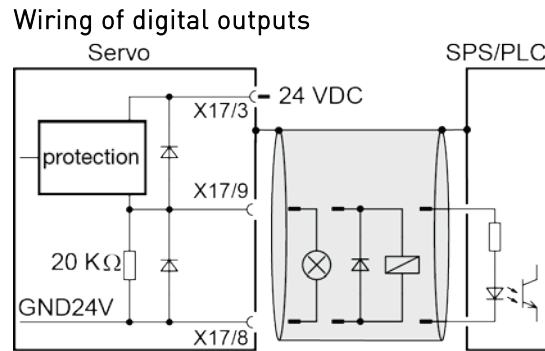

5.9 Motor connection / Output data

In diesem Kapitel finden Sie

- Output data servo modules PSD1-M 3*400 VAC 52
- Output data of power output stage at PSD1-M with 3*400 VAC power supply of the mains modules..... 52
- X45: Motor Connection (PSD1-M) 53
- X43: Motor Connection (PSD1M_1800)..... 53

5.9.1. Output data servo modules PSD1-M 3*400 VAC

Category	Specifications		
Controller type	Number of power output stage	Rated Output Current [A _{rms}]	Pulse current for 2 s [A _{rms}]
PSD1-M_1300	1	5	10
PSD1-M_1400	1	8	16
PSD1-M_1600	1	15	30
PSD1-M_1800	1	30	60
PSD1-M_2220	2	2 + 2	4 + 4
PSD1-M_2330	2	5 + 5	10 + 10
PSD1-M_2440	2	8 + 8	16 + 16
PSD1-M_2630	2	15 + 5 *	30 + 10
PSD1-M_3222	3	2 + 2 + 2	4 + 4 + 4
PSD1-M_3433	3	8 + 5 + 5 *	16 + 10 + 10

* Maximum sum current per device: 16 A.

5.9.2. Output data of power output stage at PSD1-M with 3*400 VAC power supply of the mains modules

Category	Specifications				
Device type	2 A	5 A	8 A	15 A	30 A
Input voltage	300 ... 750 VDC				
Output voltage	3x 0-400 V (0...450 Hz)				
Output nominal current	2 A _{rms}	5 A _{rms}	8 A _{rms}	15 A _{rms}	30 A _{rms}
Pulse current for 2 s	4 A _{rms}	10 A _{rms}	16 A _{rms}	30 A _{rms}	60 A _{rms}
Power at continuous operation	1.2 kVA	3 kVA	4.8 kVA	9 kVA	18 kVA
Switching frequency of power output stage	8 kHz	8 kHz	8 kHz	4 kHz	4 kHz
Heat dissipation for In	20 W	45 W	75 W	105 W	220 W





5.9.3. X45: Motor Connection (PSD1-M)

Motor connection for 3 axes

The respective pins are not assigned with 1- or 2-axis devices!

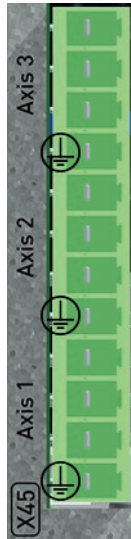

Designation	Axis	Motor cable lead designation*		
CU	3	U / L1	1	U1
CV	3	V / L2	2	U2
CW	3	W / L3	3	U3
FE	3	YE / GN		
BU	2	U / L1	1	U1
BV	2	V / L2	2	U2
BW	2	W / L3	3	U3
FE	2	YE / GN		
AU	1	U / L1	1	U1
AV	1	V / L2	2	U2
AW	1	W / L3	3	U3
FE	1	YE / GN		

* Depending on cable type.

FE: Functional ground

Shielding connection of the motor cable

The cable must be fully-screened and connected to the device housing. Use the cable clamps/shield connecting terminals furnished with the device.

The shield of the cable must also be connected with the motor housing. The fixing (via plug or screw in the terminal box) depends on the motor type.

5.9.4. X43: Motor Connection (PSD1M_1800)

Motor Connection for PSD1M_1800 (30 A)

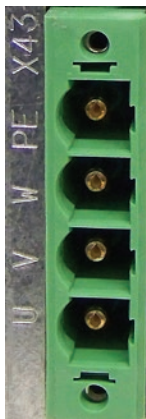

Designation	Axis	Motor cable lead designation*		
U	1	U / L1	1	U1
V	1	V / L2	2	U2
W	1	W / L3	3	U3
PE	1	YE / GN		

* Depending on cable type.

Shielding connection of the motor cable

The cable must be fully-screened and connected to the device housing. Use the cable clamps/shield connecting terminals furnished with the device.

The shield of the cable must also be connected with the motor housing. The fixing (via plug or screw in the terminal box) depends on the motor type.





5.10 X46: Connection of motor brake (PSD1-M)

Connection for 3 axes

The respective pins are not assigned with 1- or 2-axis devices!

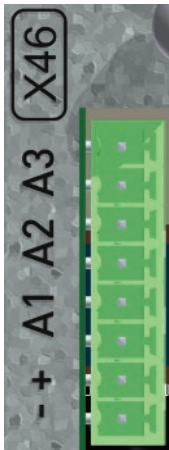

Pin		Designation	Axis	Motor cable lead designation*		
1	A3	Motor holding brake +	3	WH	4	Br1
2	A3	Motor holding brake -	3	BK	5	Br2
3	O2	Motor holding brake +	2	WH	4	Br1
4	O2	Motor holding brake -	2	BK	5	Br2
5	O1	Motor holding brake +	1	WH	4	Br1
6	O1	Motor holding brake -	1	BK	5	Br2
7	+	Input power supply brake 24 VDC	1 ... 3			
8	-	GND24 VDC	1 ... 3			

* Depending on cable type.

5.11 X44: Connection of motor brake (PSD1M_1800)

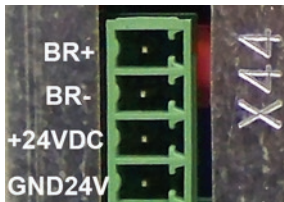

Pin		Designation	Motor cable lead designation*		
1	O1	Motor holding brake +	WH	4	Br1
2	O1	Motor holding brake -	BK	5	Br2
3	+	Input power supply brake 24 VDC			
4	-	GND24 VDC			

* Depending on cable type.

5.12 X48: HIPERFACE DSL® & Motor temperature sensor (PSD1-M)

HIPERFACE DSL® Feedback - and motor temperature sensor - connection for 3 axes

The respective pins are not assigned with 1- or 2-axis devices!

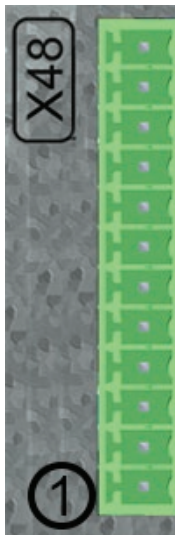

Pin	Designation	Axis	
1	PTC+	1	Temperature sensor + motor 1
2	PTC-	1	Temperature sensor - Motor 1
3	PTC+	2	Temperature sensor + motor 2
4	PTC-	2	Temperature sensor - Motor 2
5	PTC+	3	Temperature sensor + motor 3
6	PTC-	3	Temperature sensor - Motor 3
7	DSL+	1	
8	DSL-	1	
9	DSL+	2	
10	DSL-	2	
11	DSL+	3	
12	DSL-	3	

Operation only with Parker HIPERFACE DSL® cable (see page 84)!
Please contact us if you want to use a different cable.





5.13 Mains module PSD1-M_P

In diesem Kapitel finden Sie

- Connector overview PSD1-M_P (Mains module) 55
- P1: Status - LEDs - indication (Mains module)..... 58
- S2: Modes switch (Power module)..... 59
- S3: Voltage switch (Power Module) 59
- Connections of the axis system 59
- X9: Control voltage 24 VDC mains module 60
- X41 Mains supply (mains module PSD1-M_P) 61
- X40: Braking resistor / Temperature switch PSD1-M_P (Power supply)..... 63
- X4: Inputs / Outputs of the mains module 64

5.13.1. Connector overview PSD1-M_P (Mains module)

In diesem Kapitel finden Sie

- Front view (PSD1-M_P Mains Module) 55
- View from below (PSD1-M mains module)..... 57

5.13.1.1 Front view (PSD1-M_P Mains Module)

CAUTION: Risk of electric shock



Caution - Risk of electric shock!

Before wiring or loosening electrical connections please observe the following:



- Risk of electric shock, disconnect power before removing cover resp. disconnect the devices from the mains supply.
- **Caution!** Dangerous electrical voltage even after turning off the intermediate capacitors:
Up to 3 minutes with PSD1-S and 10 minutes with PSD1-M after switching off mains supply, dangerous voltages may still be present.
 Please check that no voltages are present (<50 V) at the output terminals DC+ and DC- of PSD1-S: X63/3 & X63/5 and with PSD1-M: Bus HV DC - 3 & 5. rail.





P1: Device Status LED
 S2: Operation Mode
 S3: Power Voltage
 X4: Inputs / Outputs

X9: 24 VDC Control Voltage

24 VDC & DC Power

Below Mains supply, Ballast Resistor, Central Ground

P1	Status LEDs
S2 (see page 59)	Modes switch
S3 (see page 59)	Power supply requirements setting
X4 (see page 64)	Digital Inputs / Outputs
X9 (see page 60)	Control Voltage 24 VDC
24 VDC & DC power (see page 59)	Behind the yellow protective covers you can find the rails for the supply voltage connection. <ul style="list-style-type: none"> • 24 VDC-Power supply • DC Power Voltage Supply
View from below (see page 57)	





5.13.1.2 View from below (PSD1-M mains module)

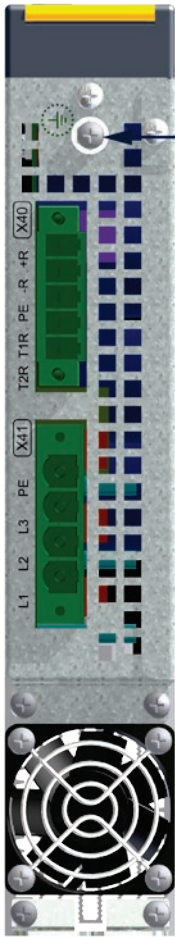

Central ground connection

X40: Ballast Resistor Temperatur Switch

X41: Mains Supply

Front view (see page 55)	
X40 (see page 63)	Brake resistor
X41 (see page 61)	Power supply
Central ground connection	Connect ground via ring cable lug with a 10 mm ² copper cable to central ground





5.13.2. P1: Status - LEDs - indication (Mains module)

P1 status	Green LED a (left)	Red LED b (right)	Status of the outputs X4
24 VDC control voltage missing or out of range	off	off	All Outputs = Low
Device ready	on	off	Ready A0 = high Warning A1 = High
One or multiple errors occurred (Error number to be displayed after 5 s)*	off	power on (5s)	Ready A0 = Low Warning A1 = High
Intermediate circuit is loaded, Control voltage OK, Drive Healthy	flashes quickly	off	Ready A0 = Low Warning A1 = High
Error digital outputs	off	flashes quickly	Ready A0 = Low Warning A1 = High
Error over-temperature or overloads	off	flashes slowly	Ready A0 = Low Warning A1 = Low
Pre-warning active	on	flashes slowly	Ready A0 = high Warning A1 = Low
Device in "bootloader" status	flashes slowly	flashes slowly	All Outputs = Low
Waiting for release by input 1	flashes slowly	off	Ready A0 = Low Warning A1 = High

*Display of error numbers by flash sequence

Green LED: Tens digit

1 flash = 10; 2 flashes = 20; 3 flashes = 30; ...

Red LED: Single-figure

1 flash = 1; 2 flashes = 2; 3 flashes = 3; ...

Adding both values results in the error number.

Display sequence:

- Green LED = OFF, red LED on for 5 s
- Green LED 1 ... 9 flashes, depending on the error number.
- Red LED 1 ... 9 flashes, depending on the error number.
- Green LED off and red LED off for 1 s).

This sequence repeats until the error is reset.

Meaning of the error numbers

- | | |
|----|--|
| 11 | Phase error |
| 12 | Voltage DC Bus too low |
| 13 | Voltage DC Bus too high |
| 21 | Temperature in the rectifier too high |
| 22 | Braking circuit overloaded |
| 23 | Temperature in the braking resistor too high |
| 24 | Short-circuit in the braking circuit |
| 25 | Rectifier overloaded |
| 31 | Voltage DC Bus too high |
| 32 | Voltage offset DC Bus too high |
| 41 | Overcurrent at digital Output |
| 51 | None or wrong EEPROM - Data |



Caution - Risk of electric shock!

High voltage supply may be present even with missing voltage supply (both LEDs off)!



**5.13.3. S2: Modes switch (Power module)**

Switch position	Operating mode
0	standard
1	Increased performance by line choke mode Warning! Operating without line choke can destroy the device.
2 ... F	Not defined

Acceptance of the switch position when switching on 24 VDC Control voltage.

5.13.4. S3: Voltage switch (Power Module)

Switch position	Supply-voltage	Load Circuit		U _{max} [VDC]
		Turn-on threshold [VDC]	Turn-off threshold [VDC]	
0	3AC400V	780	770	810
1	3AC110V	780	770	810
2	3AC230V	780	770	810
3	3AC380V	780	770	810
4	3AC480V	780	770	810
5	3AC230V	390	380	410
6	3AC110V	390	380	410
7	1AC230V*	390	380	410
8	1AC110V*	390	380	410
9 ...F	factory use			

Acceptance of the switch position when switching on 24 VDC Control voltage

NOTICE

Operation with switch positions 9 ... F can destroy the device

WARNING

* Switch positions 7 and 8 are intended solely for commissioning!
Continuous mode in this switch position is not allowed.

5.13.5. Connections of the axis system

The axis controllers are connected to the supply voltages via rails.

- Supply voltage 24VDC
- DC power voltage supply

The rails can be found behind the yellow protective covers. In order to connect the rails of the devices, you may have to remove the yellow plastic device inserted at the side.

DANGER

Caution - Risk of electric shock!

Always switch off devices before wiring them!

Dangerous voltages are still present until 10min. after switching off the power supply.

Please check that no voltages are present (<50 V) at the output terminals DC+ and DC- (X63/3 & X63/5).



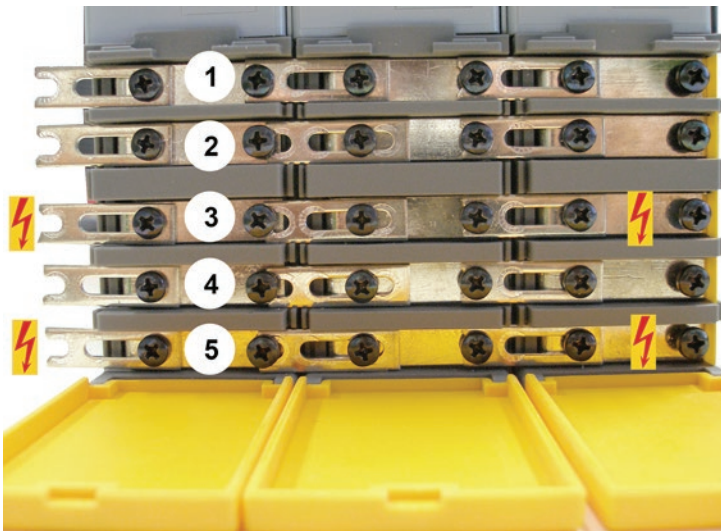

- 1 24VDC
- 2 GND24V
- 3 -HV DC
- 4 PE
- 5 +HV DC

Protective seals



Caution - Risk of electric shock!

In order to secure the contact protection against the alive rails, it is absolutely necessary to respect the following:

- Insert the yellow plastic comb at the left and right of the rails.
Make sure that the yellow plastic combs are placed at the left of the first device and at the right of the last device in the system and have not been removed.
- Setup of the devices only with closed protective covers.



External components **may not** be connected to the rail system.

Protective seals



Caution!

The user is responsible for protective covers and/or additional safety measures in order to prevent damages to persons and electric accidents.

5.13.6. X9: Control voltage 24 VDC mains module

Connector X9

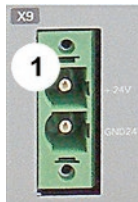

Pin	Designation
1	+24V
2	GND24V

Line cross sections:
 minimum: 0.5mm² with conductor sleeve
 maximum: 6mm² with conductor sleeve
 (AWG: 20 ... 10)

Device type	PSD1-M_P
Voltage operating range	21 - 27VDC
Ripple	0,5Vpp
Requirement according to safe extra low voltage (SELV)	yes (class 2 mains module)
Electric current drain	PSD1-M_P010: 0.2A PSD1-M_P020: 0.3 A



**5.13.7. X41 Mains supply (mains module PSD1-M_P)****⚠ WARNING****Device protection**

By cyclically switching on and off the power voltage, the input current limitation can be overloaded, which may cause damage to the device.
Wait at least one minute between two switching on processes!

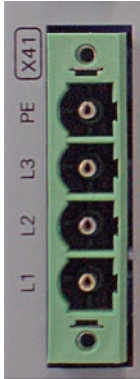
5.13.7.1 X41 Mains supply PSD1-M_P connector assignment

Pin	Designation
PE	Earth conductor
L3	Phase 3
L2	Phase 2
L1	Phase 1

⚠ WARNING

Only three-phase operation of the PSD1-M_P devices is permitted!

⚠ DANGER**Caution - Risk of electric shock!**

Always switch off devices before wiring them!

Dangerous voltages are still present until 10min. after switching off the power supply.

Please check that no voltages are present (<50 V) at the output terminals DC+ and DC- (X63/3 & X63/5).

5.13.7.2 Mains Connection Power module PSD1-M_P010 with line choke

Category	Specifications		
	230 V	400 V	480 V
PSD1-M_P010			
Mains voltage	230 VAC ±10 % 50-60 Hz	400 VAC ±10 % 50-60 Hz	480VAC ±10% 50-60Hz
Rated voltage	3 AC 230 V	3 AC 400 V	3 AC 480 V
Input Current	22 Arms	22 Arms	18 Arms
Output voltage	325 VDC ±10 %	565 VDC ±10 %	680 VDC ±10 %
Output power	6 kW	10 kW	10 kW
Pulse power (<5 s)	12 kW	20 kW	20 kW
Power dissipation	60 W	60 W	60 W
Maximum fuse rating per device	Measure for line and device protection: UL listing (DIVQ) fuses Manufacturer: ABB, Stotz-Kontakt GmbH (E212323) Model No.: S203UP-K, 1 fuse 480 VAC, 3-phase, 25 A, operating temperature 55 °C		





5.13.7.3 Mains connection Power module PSD1-M_P010 with line choke

Increased power by means of a line choke (see page 90)

Category	Specifications		
PSD1-M_P010 with line choke	230 V	400 V	480 V
Mains voltage	230 VAC $\pm 10\%$ 50-60 Hz	400 VAC $\pm 10\%$ 50-60 Hz	480VAC $\pm 10\%$ 50-60Hz
Rated voltage	3 AC 230 V	3 AC 400 V	3 AC 480 V
Input Current	24.5 A	24.5 A	20.4 A
Output voltage	325 VDC $\pm 10\%$	565 VDC $\pm 10\%$	680 VDC $\pm 10\%$
Output power	9 kW	15 kW	15 kW
Pulse power (<5 s)	18 kW	30 kW	30 kW
Power dissipation	70 W	70 W	70 W
Maximum fuse rating per device	Measure for line and device protection: UL listing (DIVQ) fuses Manufacturer: ABB, Stotz-Kontakt GmbH (E212323) Model No.: S203UP-K, 1 fuse 480 VAC, 3-phase, 25 A, operating temperature 55 °C		
Earth leakage current	Current on the mains PE (see page 27) (>3,5 mA)		
Supply networks	Possible supply networks (see page 27): TN		



WARNING

The specified performance data are only valid in connection with line choke IND-0001-02 (see page 90).

5.13.7.4 Mains Connection Power module PSD1-M_P020 without line choke

Category	Specifications		
PSD1-M_P020	230 V	400 V	480 V
Mains voltage	230 VAC $\pm 10\%$ 50-60 Hz	400 VAC $\pm 10\%$ 50-60 Hz	480VAC $\pm 10\%$ 50-60Hz
Rated voltage	3 AC 230 V	3 AC 400 V	3 AC 480 V
Input Current	44 Arms	44 Arms	35 Arms
Output voltage	325 VDC $\pm 10\%$	565 VDC $\pm 10\%$	680 VDC $\pm 10\%$
Output power	12 kW	20 kW	20 kW
Pulse power (<5 s)	24 kW	40 kW	40 kW
Power dissipation	120 W	120 W	120 W
Maximum fuse rating per device 2 special purpose fuses in line are required	Cable protection measure: MCB (K characteristic) with a rating of 50A / 4xxVAC (depending on the input voltage) Recommendation: (ABB) S203U-K50 (440VAC) Device protection measure: Circuit breakers 80A / 700VAC per supply leg in accordance with UL category JFHR2 Requirement: Bussmann 170M1366 or 170M1566D		





5.13.7.5 Mains connection Power module PSD1-M_P020 with line choke

Increased power by means of a line choke (see page 90)

Category	Specifications		
	230 V	400 V	480 V
PSD1-M_P020 with line choke			
Mains voltage	230 VAC $\pm 10\%$ 50-60 Hz	400 VAC $\pm 10\%$ 50-60 Hz	480VAC $\pm 10\%$ 50-60Hz
Rated voltage	3 AC 230 V	3 AC 400 V	3 AC 480 V
Input Current [rms]	44 A	44 A	40 A
Output voltage	325 VDC $\pm 10\%$	565 VDC $\pm 10\%$	680 VDC $\pm 10\%$
Output power	15.5 kW	27 kW	30 kW
Pulse power (<5 s)	31 kW	54 kW	60 kW
Power dissipation	140 W	140 W	140 W

Maximum fuse rating per device 2 special purpose fuses in line are required	Cable protection measure: MCB (K characteristic) with a rating of 50A / 4xxVAC (depending on the input voltage) Recommendation: (ABB) S203U-K50 (440VAC) Device protection measure: Circuit breakers 80A / 700VAC per supply leg in accordance with UL category JFHR2 Requirement: Bussmann 170M1366 or 170M1566D
Earth leakage current	Current on the mains PE (see page 27) (>3,5 mA)
Supply networks	Possible supply networks (see page 27): TN

**WARNING**

The specified performance data are only valid in connection with line chokes (see page 90) IND-0002-01 or IND-0002-02 (UL).

5.13.8. X40: Braking resistor / Temperature switch PSD1-M_P (Power supply)

The energy generated during braking operation must be dissipated via a braking resistor.



Pin	Description
+R	+ Braking resistor
-R	- Braking resistor
PE	PE
T1R	Temperature Switch
T2R	Temperature Switch

short-circuit proof!

Device type	PSD1-M_P010	PSD1-M_P020
Capacity/ storable energy	550 μ F/ 92 Ws at 400 V 53 Ws at 480 V	1175 μ F/ 197 Ws at 400 V 114 Ws at 480 V
Minimum braking resistance	27 Ω	10 Ω
Recommended nominal power rating	500 ... 1500 W	500...5000 W
Pulse power for 1s	22 kW	60 kW
Maximum permissible continuous current	13 A	25 A

Maximum capacity in the axis system:

- PSD1-M_P010: 2400 μ F
- PSD1-M_P020: 5000 μ F





Reference value for the required capacity in an axis system

100 μF per kW of the temporal medium value of the total power (transmissions + power dissipation) in the axis system.

Example: PSD1-M_P020 (1175 μF) with one axis controller (440 μF)

Total power 15 kW, 100 $\mu\text{F}/\text{kW} \Rightarrow$ 1500 μF required in the axis system.

Axis system: 1615 μF are sufficient.

Connection of a braking resistor on PSD1-M_P (mains module)

Minimum line cross section:	1.5 mm ²
Maximum line length:	2 m
Maximum intermediate circuit voltage:	Depending on the position of the switches on the power module (see page 59)
Switch-on threshold:	
Hysteresis	

5.13.8.1 Temperature switch mains module X40

Connector X40 Pin T1R, T2R

Temperature monitoring:

The temperature switch (normally closed contact) must be connected, unless an error message will be issued.

Temperature switch/relay

No galvanic separation, the temperature sensor (normally closed contact) must comply with the safe separation according to EN 60664.

If there is no temperature monitoring due to the connected braking resistor, the T1R and T2R connections must be connected by a jumper.

CAUTION

Caution!

Without temperature monitoring, the braking resistor might be destroyed.

5.13.9. X4: Inputs / Outputs of the mains module

Pin	Name	Function
1	24 VDC (output)	+24 VDC output (max. 340 mA)
2	GND24V	GND24V
3	24 VDC Dout (input)	24 VDC supply for outputs 0 ... 3
4	Nc	-
5	Input 0	Enable (High=Enable, Low=Disable)
6	Input 1	Quit (positive edge)
7	Input 2	Not defined
8	Input 3	Not defined
9	Output 0	Ready (High=ready , Low=not ready)
10	Output 1	Warning (High = no warning , low = warning)*
11	Output 2	Not defined
12	Output 3	Not defined
13	factory use	
14	factory use	

NOTICE

Axes must only be energized if A0 = ready = high!

- * Warning Capacity utilization of DC Bus = 90%
- Temperature alarm: Rectifier 5 K to switch-off threshold





5.14 X60: PC-/Diagnostic interface

Wiring with Ethernet Crossover cable Cat5e; for this, we offer our **CBD000C0-T00-T0** (see page 95) interface cable.

Standard Ethernet Address of the PSD:192.168.10.x

The final position (x) is set via the address adder S12 (higher value byte) & S13 (low value byte) and accepted by Power On.

Address setting

Settings:

S12: Device address higher value half-byte (accept with power ON)

S13: Device address low value half-byte (accept with power ON)

Example: S12=2, S13=1

Address= 0x21: $S12 \cdot 16 + S13 = 33$

Addresses 0 and 241 ... 255 are not possible.

Connection is configured in PSD ServoManager.

5.15 Communication interfaces

5.15.1. X61, X62 Ethernet Connection

RJ45-Socket: Assignment

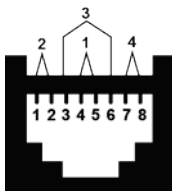

Pin	Wire pair No.	RJ45 (X61)	RJ45 (X62)
		out	in
1	2	Tx +	Tx +
2	2	Tx -	Tx -
3	3	Rx +	Rx +
4	1	-	factory use
5	1	-	factory use
6	3	Rx -	Rx -
7	4	-	factory use
8	4	-	factory use

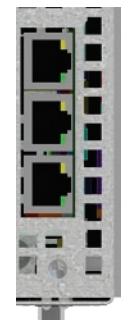

X62: Fieldbus interface in
X61: Fieldbus interface out
X60: PC interface

Wiring with Ethernet Crossover cable Cat5e (from X61 to X62 of the next device without termination); for this, we offer our **CBD000C0-T00-T0** (see page 95) interface cable.





6. Safe Torque Off (STO) with PSD1

In this chapter you can read about:

- General Description 66
- STO Operating Principle 68
- Notes on the STO function 72
- Conditions of utilization for the STO function 73
- STO delay times 74
- STO Application examples 74
- STO function test 79
- Technical data STO 81

6.1 General Description

In diesem Kapitel finden Sie

- Important Technical Terms and Explanations 66
- Applications in accordance with the Regulations 67
- Advantages of using the "safe torque off" safety function" STO 68

The following documentation is meant to provide the basic information concerning our drive controller and an understanding about the advanced, safety oriented machine construction. References to standards or other regulations are made in a general overview manner. The specific standards or regulations for your installation will vary depending upon the equipment employed and the specifics of your application.

For complementary information, we recommend the respective technical literature.

6.1.1. Important Technical Terms and Explanations

Term	Explanation
Safety category 3 in accordance with EN ISO 13849-1	Definition according to standard: Circuit with built-in protective functions for individual fault conditions. Some, but not all faults will be recognized. The frequent occurrence of fault conditions can lead to a loss of the safety functions. The remainder of the risk must be understood and accepted. The determination for the application of the appropriate safety category requirements, (risk analysis), lies with the installer and operator of the equipment. It can take place according to the method described in EN ISO 13849-1, appendix A.
"Safe torque off" or abbreviated: STO=Safe torque off	With the "safe torque off", the energy supply of the drive is safely interrupted according to EN 1037, paragraph 4.1. The drive is not to be able to produce a torque and thus dangerous movements (see EN 1037, paragraph 5.3.1.3). The standstill position must not be monitored. If an external force effect, e.g. a drop of hanging loads, is possible with the "safe torque off", additional measures to safely prevent those must be provided (e.g. additional mechanical brakes). The following measures are appropriate for a "safe torque off": Contactor between mains and drive system (mains contactor) Contactor between power section and motor (motor contactor) Safe blocking of the power semiconductor control (start inhibitor)
Start-Up Lockout	Safe blocking of the power semiconductor control. With the aid of this function, you can obtain a "safe torque off".



**Stop categories according to EN60204-1 (9.2.2)**

Stop-Category	Safety function	Requirement	System Behaviour	Remark
0	Safe Torque Off (STO)	Stopping by immediately switching off the energy supply of the machine drive elements	Uncontrolled stop	Uncontrolled stop is the stopping of a machine movement by switching off the energy of the machine drive elements. Available brakes and/or other mechanical stopping components are applied.
1	Safe stop 1 (SS1)	Stop where the energy of the machine drive elements is maintained in order to reach a stop. The energy supply is only interrupted, if the standstill is attained.	Controlled stop	Controlled stop is the stopping of a machine movement by for instance resetting the electrical command signal to zero, as soon as the stop signal has been detected by the controller, the electrical energy for the machine drive elements remains however during the stopping procedure.
2	Safe stop 2 (SS2)	Stop where the energy to the machine drive elements is maintained.	Controlled stop	This category is not covered.

6.1.2. Applications in accordance with the Regulations

The Servo Drive PSD supports the "safe torque off" (STO) safety function, with protection against unexpected startup according to the requirements of EN ISO 13849-1, category 3 to PLe and EN 1037.

Together with the external safety control device, the "safe stop 1" (SS1) safety function according to the requirements of DIN EN 61800-5-2:2008 category 3 can be used. As the function is however realized with the aid of an individually settable time delay on the safety control, it must be taken into account that, due to an error in the drive system during the active braking phase, the motor coasts uncontrolled or may even accelerate actively in the worst case until the expiry of the preset switch-off time.

A risk evaluation which must be carried out according to the machine standard 2006/42/EG resp. EN ISO 12100 and EN ISO 13849-1, the machine manufacturer must project the safety system for the entire machine including all integrated components. This does also include the electrical drives.

Qualified Personnel

Planning, installation and initial system commissioning require a detailed understanding of this information.

Standards and accident prevention regulation associated with the application must be known and respected as well as risks, protective and emergency measures.

Many years of experience in machine safety with drives are necessary.





6.1.3. Advantages of using the "safe torque off" safety function" STO

Safety category 3 in accordance with EN ISO 13849-1

Requirements performance features	Use of the safe torque off function	Conventional solution: Use of external switching elements
Reduced switching overhead	Simple wiring, certified application examples Grouping of drive controllers on a mains contactor is possible.	Two safety-oriented power contactors in series connection are required.
Use in the production process High operating cycles, high reliability, low wear	Extremely high operating cycles thanks to almost wear-free technology (low-voltage relay and electronic switch). The "safe torque off" status is attained due to the use of wear-free electronic switches (IGBTs).	This performance feature cannot be reached with conventional technology.
Use in the production process High reaction speed, fast restart	Drive controller remains performance- and control-oriented in connected state. No significant waiting times due to restart.	When using power contactors in the supply, a long waiting time for the energy discharge of the DC link circuit is required. When using two power contactors on the motor side, the reaction times may increase, you must however take into consideration other disadvantages: a) Securing that switching takes only place in powerless state (Direct current! Constant electric arcs must be prevented). b) Increased overhead for EMC conform wiring.
Emergency-stop function	Allowed	Allowed

6.2 STO Operating Principle

In diesem Kapitel finden Sie

- STO principle with PSD1-S..... 69
- STO principle of PSD1-S with one axis module 69
- STO principle of PSD1-M with two axis modules 70
- STO principle of PSD1-M with three axis modules 71

Principle

The current flow in the motor windings is controlled by a power semiconductor bridge (6-fold IGBT).

A rotating field is created via the processor by means of the power output stage. Between control logic and power module, optocouplers are used for potential separation.

The STO input are on the front panel. 2 optocouplers are controlled via 2 STO channels (STOA/ & STOB/). At a STO via external safety control both auxiliary power supplies of the power output stage are switched off via 2 channels. Due to this fact the power semiconductor bridge is blocked and there is no motor current.

The reset procedure of the Safe Torque Off depends on the configured settings of the object STO_Setup.

At standard settings STO_Setup=0 the motor may be powered as soon as STOA/ and STOB/ inputs are reset to high level.

At settings STO_Setup=1 the generated error 0x5492 needs be acknowledged before the motor can be powered again.

Detection of hardware failure

An internal Hardware monitoring recognizes the failure of the optocoupler by continuously comparing both channels. If the monitoring system recognizes a discrepancy for a defined time (approx. 10 s) the fault is stored in the hardware. This is reported via the error code 0x5493 ?.

The error can only be reset by a hardware reset (switching off and on the servo drive). But before the error must be found and solved by the user.



6.2.1. STO principle with PSD1-S

With the single axis drive PSD1-S STO is activated via 2 channels (STOA/ and STOB/).

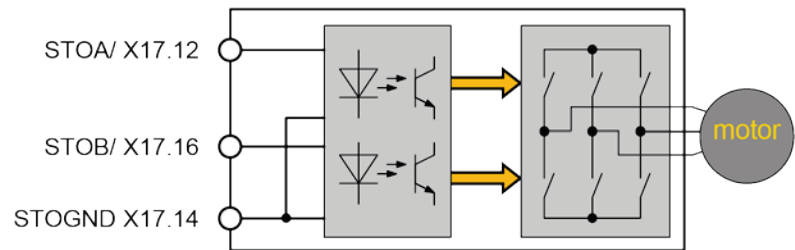

Pin	Name		Description
X17.12	STOA/*	Input	STOA/ = 0 V Motor deactivated
X17.16 (see page 35)	STOB/*	Input	STOB/ = 0 V Motor deactivated
			STOA/ = 24 VDC and STOB/ = 24 VDC Motor released
X17.14	STOGND*	Input	STO Ground. Ground of the external 24 VDC must be connected to the central ground connection (bottom of the device).

* The inputs are optically isolated.

6.2.2. STO principle of PSD1-S with one axis module

At the PSD1-M with one axis module, STO is activated via 2 channels (STOA1/ und STOB1/).

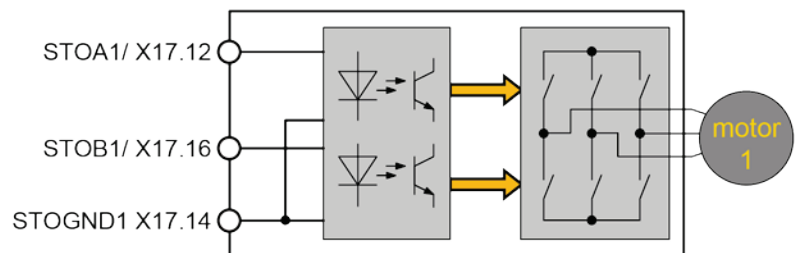

Pin	Name		Description
X17.12	STOA1/*	Input	STOA1/ = 0 V Motor deactivated
X17.16 (see page 49)	STOB1/*	Input	STOB1/ = 0 V Motor deactivated
			STOA1/ = 24 VDC and STOB1/ = 24 VDC Motor released
X17.14	STOGND1*	input	STO Ground. Ground of the external 24 VDC must be connected to the central ground connection (bottom of the device).

* The inputs are optically isolated.



6.2.3. STO principle of PSD1-M with two axis modules

At the PSD1-M drive with two axis modules, STO is activated via 2 channels for each motor (STOA1/ and STOB1/ for motor 1 and STOA2/ and STOB2/ for motor 2).

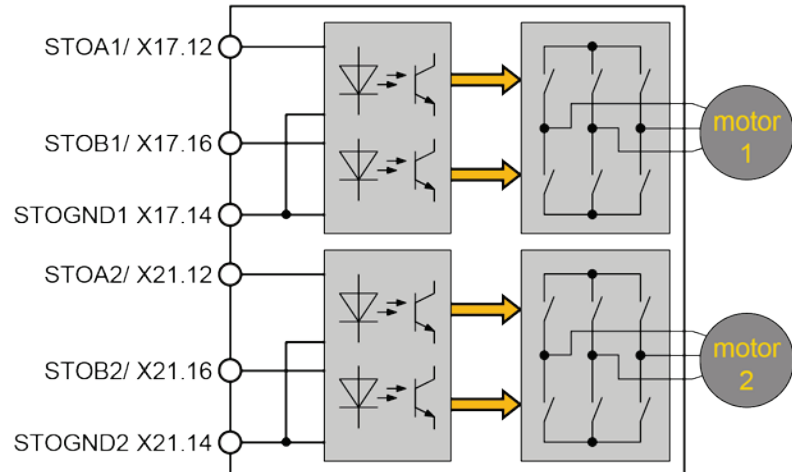

Pin	Name		Description
X17.12 <small>(see page 49)</small>	STOA1/*	Input	STOA1/ = 0 V Motor 1 deactivated
			STOB1/ = 0 V Motor 1 deactivated
X17.16	STOB1/*	Input	STOA1/ = 24 VDC and STOB1/ = 24 VDC Motor 1 released
X17.14	STOGND1*	Input	STO Ground. Ground of the external 24 VDC must be connected to the central ground connection (bottom of the device).
X21.12 <small>(see page 50)</small>	STOA2/*	Input	STOA2/ = 0 V Motor 2 deactivated
			STOB2/ = 0 V Motor 2 deactivated
X21.16	STOB2/*	Input	STOA2/ = 24 VDC and STOB2/ = 24 VDC Motor 2 released
X21.14	STOGND2*	input	STO Ground. Ground of the external 24 VDC must be connected to the central ground connection (bottom of the device).

* The inputs are optically isolated.





6.2.4. STO principle of PSD1-M with three axis modules

At the PSD1-M drive with three axis modules, STO for motor 1 is activated via 2 channels (STOA1/ and STOB1/ and for the motors 2 & 3 via two further channels (STOA2/ & STOB2/).

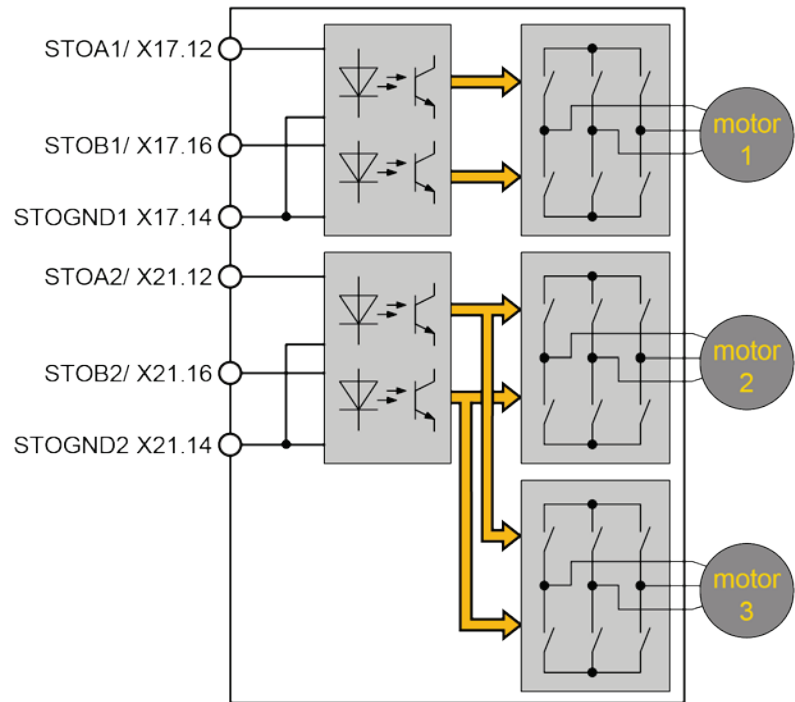

Pin	Name		Description
X17.12	STOA1/*	Input	STOA1/ = 0 V Motor 1 deactivated
X17.16 (see page 49)	STOB1/*	Input	STOB1/ = 0 V Motor 1 deactivated
			STOA1/ = 24 VDC and STOB1/ = 24 VDC Motor 1 released
X17.14	STOGND1*	Input	STO Ground. Ground of the external 24 VDC must be connected to the central ground connection (bottom of the device).
X21.12	STOA2/*	Input	STOA2/ = 0 V Motor 2 & 3 deactivated
X21.16 (see page 50)	STOB2/*	Input	STOB2/ = 0 V Motor 2 & 3 deactivated
			STOA2/ = 24 VDC and STOB2/ = 24 VDC Motor 2 & 3 released
X21.14	STOGND2*	Input	STO Ground. Ground of the external 24 VDC must be connected to the central ground connection (bottom of the device).

* The inputs are optically isolated.





6.3 Notes on the STO function

DANGER

- It should be noted in connection with the STO application examples illustrated here that after the Emergency stop switch has been activated, no galvanic isolation in accordance with EN 60204-1 Section 5.5 is guaranteed. This means that the entire system must be disconnected from the mains power supply with an additional main switch or mains power contactor for repair jobs. Please note in this context, that even after the power is disconnected, dangerous electrical voltages may still be present in the drive for about 10 minutes.
- During the active braking phase of Stop category 1 (controlled bringing to a stop with safely monitored delay time according to EN60204-1) or safe stop 1, faulty function must be expected. If an error in the drive system occurs during the active braking phase, the axis may trundle to an unguided stop or might even actively accelerate until the expiry of the defined switch-off time.
- As soon as Setup-mode is activated in the PSD ServoManager, the Fieldbus - Interface is deactivated. Then it is not possible to set a braking ramp via fieldbus.

Maintenance

- When using STO a **recorded STO - function test** (see page 79) must be carried out:
 - ◆ After commissioning and
 - ◆ in defined maintenance intervals.





6.4 Conditions of utilization for the STO function

- The STO safety function must be tested and protocolled **as described** (see page 79). The safety function must be requested at least once a week. In safety door applications, the weekly testing interval must not be observed, as you can assume that the safety doors will be opened several times during the operation of the machine.
- The PSD1 with integrated STO safety function as well as the utilized safety switching devices must be mounted protected (IP54 control cabinet).
- Basically there is only a maximum cable length of 30 m of STO inputs (X17, X21) allowed. It's not permitted to route the cables outside.
- Only qualified staff members are permitted to install the STO function and place it in service.
- The X9/2 (GND24V) terminal on the PSD1-M_P mains module respectively the X17.12 (GND24V) terminal on the PSD1-S single device must be connected to the PE protective lead. This is the only way to ensure protection against incorrect operation through earth faults (EN60204-1 Section 9.4.3)!
- When using an external safety control with adjustable delay time, (as illustrated in the STO application example), it must be ensured that the delay time cannot be adjusted by persons not authorized to do so (for example by applying a lead seal). With the UE410-MU safety control, this is not necessary, if the anti manipulation measures are respected.
- The adjustable delay time on the safety control must be set to a value greater than the duration of the braking ramp controlled by the PSD1 with maximum load and maximum speed.
Otherwise fault 0x5495 may occur.
- All conditions necessary for CE-conform operation must be observed.
- When external forces are applied to the drive axes, additional measures (e.g. additional brakes) are to be taken. Please note in particular the effects of gravity on suspended loads! This must be respected above all for vertical axes without self-locking mechanical devices or weight balance.
- When using synchronous motors, a short movement over a small angle is possible, if two errors occur simultaneously in the power section. This depends on the number of pole pairs of the motor (rotary types: 2 poles = 180°, 4 poles = 90°, 6 poles = 60°, 8 poles = 45°, Linear motors: 180° electric).





6.5 STO delay times

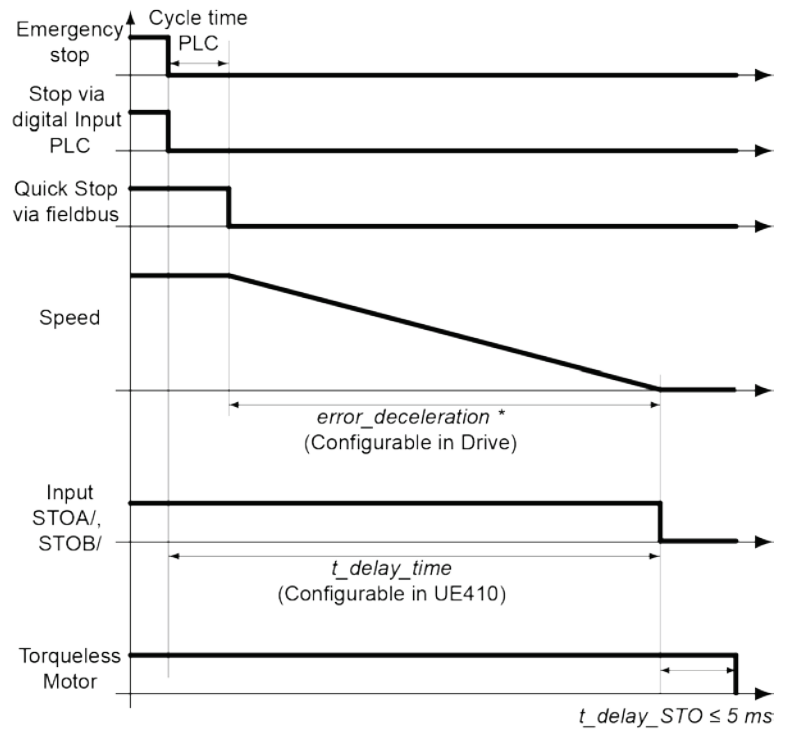

* Complies with der Quick-Stop-Ramp (0x6085.0x00); in PSD ServoManager under

Device **Axis 1** Optimization

▲ Upload device config ▼ Download device config

Navigator

- Axis 1
- Operation Mode
- World/Userunit
- Motor
- Inertia/ ext. load
- Limits
- Homing Mode
- Ramps**
- Digital Inputs/Outputs

1	= MinSlowDown (0x3428.0x00)
2	= QuickStopDecel (0x6085.0x00)

Stop (slow down) settings 1

Stop Deceleration [Units/s ²]	10000000
---	----------

Error (quick down) settings 2

Error Deceleration [Units/s ²]	10000000
--	----------

Jerk settings

Position Jerk [[500us]]	1
Jog jerk [500us]	1

Recommendation: Use the settings (default) with subsequently de-energized.





6.6 STO Application examples

6.6.1. STO and SS1 function with external safety control

In diesem Kapitel finden Sie

- Circuit Diagram..... 75
- Description 76
- Functional description..... 76
- Design Features 76
- Calculation of the total failure probability..... 77

6.6.1.1 Circuit Diagram

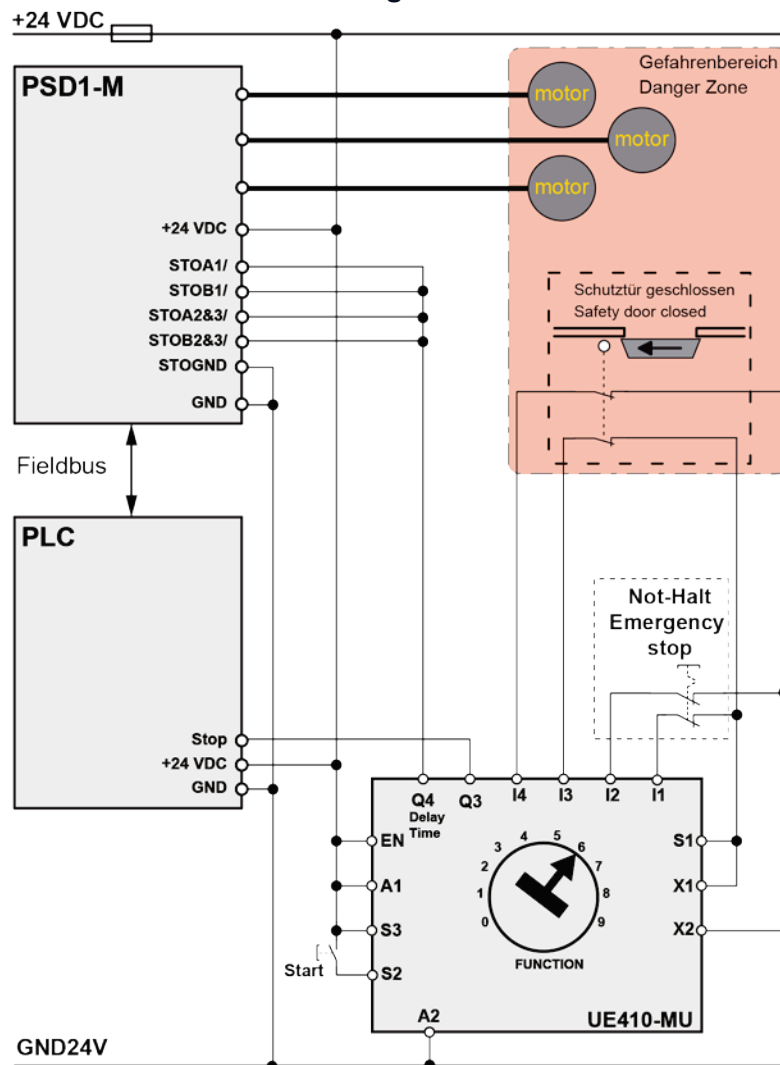



6.6.1.2 Description

The application example demonstrate how a 3-axis PSD1-M servo drive cooperates with the safety control UE410-MU of Sick and with a PLC.

The STO circuit of the 3-axis PSD1-M must support a safe stop 1 of the control with emergency stop (category 3 - PL e). The application example described here corresponds to Stop Category 1 as defined by EN60204-1.

Together with the external safety switching device, the "Safe Stop 1"(SS1) safety function can also be implemented.

A Stop Category 0 in accordance with EN 60204-1 can be implemented, for example by setting the delay time on the safety switching device to 0. The motor torque will then be turned off immediately in 2 channels and will not be able to generate any more torque. Please take into consideration that the motor will not brake and a coasting down of the motor (trundling) may result in hazards. Additionally the motor fixing brake can be damaged at braking. If this is the case, the STO function in stop category 0 is not permitted.

6.6.1.3 Functional description

- Shut-down of the motor is initiated by:
 - ◆ Activating emergency-stop or
 - ◆ Opening the safety door
- The safety control UE410-MU requires a stop from PLC via output Q3.
- Via fieldbus the PLC sends a braking ramp/ stop command to the PSD1-M for all 3 motors.
- After a delay time set in the safety control UE410-MU, STO (channel 1 & 2) is released via output Q4.
- Thus all 3 motors are placed in a moment-free condition (STO). Please take care that object STO_Setup=0 (standard settings) in order to prevent that STO is recognized as fault.
- In the Fieldbus Status Word Bit 15 STO status is displayed as slowly flashing LED.
- The delay time in the safety control must increased in such a way that, as soon as STO is released, the motors stand still by the braking ramp configured in the drive.
- The acknowledgement (start button) via the safety control UE410-MU is only necessary, if after the disabling of the STO function, a danger to any person or to the machine could arise due to automatic start-up.

6.6.1.4 Design Features

- The contacts of the emergency stop buttons and the safety door need to be designed mechanically in accordance with EN 60947-5-1 appendix K.
- Concerning the delayed STO procedure, the risk must be considered by the machine designer.
- Drive and safety control must be wired in the same control cabinet. Wiring must be in accordance with EN 60204-1.
- The operating instructions of the UE410-MU3T5 safety control must be observed.
- We recommend to use a filter > 3 ms for the signal Q3 in the PLC (stop input) as the safety control UET410-MU regularly modulates test signals on the outputs Q3 and Q4.
- Other safety controls may be used if they fulfill all requirements for category 3 PL=e and dispose of a high-quality error detection with dynamic test pulse. The max. test pulse must be <1 ms / actively low.



6.6.1.5 Calculation of the total failure probability

The failure probability of each of the two STO circuits of the servo drive is 1.0E-09 per hour. Thus the probability of a failure of the entire 3-axis servo drive is 2.0E-09 per hour.

The safety control UE410.MU is a certified component. Its failure probability is 6.0E-09 per hour.

At this calculation only the probability of a failure of the emergency stop is considered, not the contact of the safety door. With a B10d value of 100.000 cycles at 240 working days, 16 working hours and at a cycle time of 1 hour, the result for n_{op} is 3840 cycles per year and 260 years for MTTFd. As the safety control disposes of a high-quality error detection with dynamic test pulse for the input signal, a high diagnostic coverage DC for the switches can be set.

According to Sistema the total failure probability is 3.27E-8 per hour (PL=e).

6.6.2. STO function without external safety control

[In diesem Kapitel finden Sie](#)

- Circuit Diagram 77
- Functional description 78
- Design Features 78
- Calculation of the total failure probability 78

6.6.2.1 Circuit Diagram



STO from PSD1-S does not comply with EN ISO13849!
 If necessary please take care of additional safety measures for a transitional period!
 We are working on an upgrade of the PSD1-S!

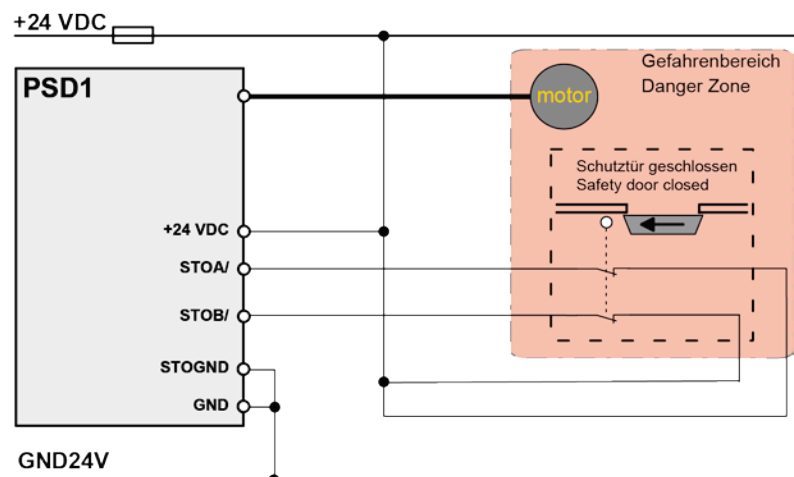

In this example we show how the contacts of the safety door can be wired to the 1-axis PSD1 without the use of a safety control.

A double-channel safety door monitoring or a double-channel emergency stop can be directly wired to the PSD1.

We do not recommend this type of wiring for vertical axes without self-locking mechanics as it may be damaged at braking with the motor holding brake by motor coasting. If this is the case we recommend to use the previous wiring type with safety control.



6.6.2.2 Functional description

- When opening the safety door, the motor is immediately switched to double-channel, moment-free mode; this complies with Stop Category 0 In accordance with EN 60204-1. In case the motor axis is still energized or moving during the triggering of the STO, error 0x5495 is triggered simultaneously. If not, no error is triggered; unless error 0x5492 is triggered at setting STO_Setup=1. Basically STO status is displayed in the Fieldbus Status Word Bit 15 and as slowly flashing LED.
- During trundling of the motor the motor brakes of the Parker motor must not be activated as otherwise they can be damaged.
- In case error 0x5492 or 0x5495 are triggered then error must be acknowledged in order to reactivate the drive. The acknowledgement is only permissible with category B. It shouldn't been used if there is a possibility to enter the dangerous area. In this case an external acknowledgement device must be used.

6.6.2.3 Design Features

- The contacts of the emergency stop buttons and the safety door need to be designed mechanically in accordance with EN 60947-5-1 appendix K.
- PSD must be located in a protected area (IP54 control cabinet). Outside this protected area, the line guiding to the external switches must be separated channelwise or must be especially protected.

6.6.2.4 Calculation of the total failure probability

The failure probability of each of the two STO circuits of the servo drive is 1.0E-09 per hour. When calculation the overall failure probability further components of the complete machine such as contacts of the safety door must be considered. Due to the hardware monitoring in the PSD servo drive, only a medium level of diagnostic coverage DC for the external contacts can be set.





6.7 STO function test

The STO-function (Safety Option S1) must be checked at:

- Commissioning
- After each exchange of any equipment within the system
- After each intervention into the system wiring
- In defined maintenance intervals (at least once per week) and after a longer standstill of the machine

If the STO function was triggered by opening a protective door and if this door is opened several times a week, the weekly testing interval is not required.

The check must be made by qualified personnel adhering to all necessary safety precautions.

The following testing steps must be performed:

STO test	Action / Function	Anticipated Result Remark, Cause of Fault Condition
1	Apply 24 VDC voltage to terminal X17.12* and X17.16* Apply 0 VDC voltage to terminal X17.14*	
2	Switch on supply power and 24 VDC supply voltage	No error must be present
3	Configuring the device	No error must be present
4	Testing active STO on terminal X17.12 and X17.16: Simultaneous removing of 24 VDC on terminal X17.12 and X17.16*	Active STO must be displayed via LED or fieldbus.** No error must be present if object STO_Setup=0. Error message 0x5492 if object STO-Setup=1.
5	Apply again 24 VDC voltage to terminal X17.12 and X17.16 and acknowledge STO afterwards*	No error must be present; torque at the motor should be present.
6	Then switch off and on again 24 VDC voltage supply.	No error must be present

* The same test with terminals X21.12 & X21.16 & X21.14 is necessary for two or three axis controllers.

** With two or three axis controllers STO status for all motors should apply.

A manual check of the torqueless drive is here also sufficient.

The triggering of the STO can also be made by actuating the emergency stop switch. During the automated test, the STO can also be triggered via the contacts of an external relay

Following the test steps

Once all of the relevant safety test steps have been accomplished, the actions taken must be documented. A protocol specimen can be found in the following section. Depending on the machine version, additional or other test steps may be required.





6.7.1. STO test protocol specimen

Project/machine:

Name of the tester:

Servo axis:

Settings

STO_Setup:

STO function test:

STO function test steps 1-6: successfully tested

Safe stop 1: successfully tested
 is not used

Initial acceptance on:

Repeat check on:

Signature of the tester

Signature of the tester





6.8 Technical data STO

Category	Specifications	
STO Certificate (http://www.Parker.com/Literature/Electromechanical/Europe/Certificates/DOC-0014-01_PSD_STO_Certificate.pdf)	According to EN ISO13849 Device certified if "STO certified" is stated in type plate (below the CE sign)	 <p>PSD1 IEC 61508:2010 SIL 3 EN 61800-5-2:2007 SIL 3 ISO 13849-1:2015 PL e ISO 13849-2:2012 SEBS-A.162311/13</p>
Nominal voltage of the inputs	24 VDC	
Required isolation of the 24V control voltage	Grounded protective extra low voltage, PELV	
Fuse protection	Protection of the STO control voltage: 1 A	
Number of inputs Signal inputs via optocoupler	2 Low = 0 ... 5 V DC or open High = 15 ... 26.4 VDC I_{in} at 24 VDC: 9 mA +/- 1 mA	
STO Input A, Level	Low or open = STO activated High = STO deactivated Reaction time max. 5 ms	
STO Input B, Level	Low or open = STO activated High = STO deactivated Reaction time max. 5 ms	
Switch-off time	Switch-off time with unequal input statuses: 10 s (max. error reaction time)	
Maximum tolerable test pulse time	Maximum tolerable test pulse time (low active) for external safety control: 1 ms	
Grouping of safety level	<ul style="list-style-type: none"> • Category 3 • PL=e • SIL 3 • PFHd=1.00E-9 per STO circuit • Mission time: 20 years • MTTFd = 800 years (when using EN ISO 13849-1 the MTTFd value must be limited to 100 years) 	





7. Accessories

In this chapter you can read about:

- SMH Servo Motors with HIPERFACE DSL® - Feedback 83
- EMC measures 84
- External braking resistors 91
- Interface Cables 95





7.1 SMH Servo Motors with HIPERFACE DSL® - Feedback

Low Inertia Servo Motors - SMH

Product Overview

Description

The SMH Series of highly-dynamic brushless servo motors have been design to combine the cuttingedge technology of Parker Hannifin products with extremely high performance.

Thanks to the innovative "salient pole" technology, the motor's dimensions are considerably reduced with significant advantages in terms of specific torque, overall dimensions and dynamic performance. Compared to traditional-technology brushless servo motors, the specific torque is approximately 30 % higher, overall dimensions are considerably reduced and, consequently rotor inertias are extremely low. Thanks to the high quality of Neodymium-Iron-Boron magnets, and also the encapsulation method used to fasten them to the shaft, the SMH motors can achieve very high acceleration and withstand high overloads without risk of demagnetisation or detachment of the magnets.

Specific applications for the SMH Series include all types especially those for the packaging and handling industry, and all those applications where very high dynamic performances and very low inertias are required.

Features

- Single Cable solution (Hiperface DSL® feedback)
- Further Feedback support: Resolver, Hiperface and EnDat interface, Hall sensors, rotary and linear encoders
- Customised windings/voltages
- Increased Inertia option
- Multiple connection options

Application

- Packaging Machinery
- Food & Beverage
- Pharma
- Material Handling
- Material Forming
- Factory Automation
- In-Plant Automotive
- Robotics
- Printing
- Servo Hydraulic Pumps

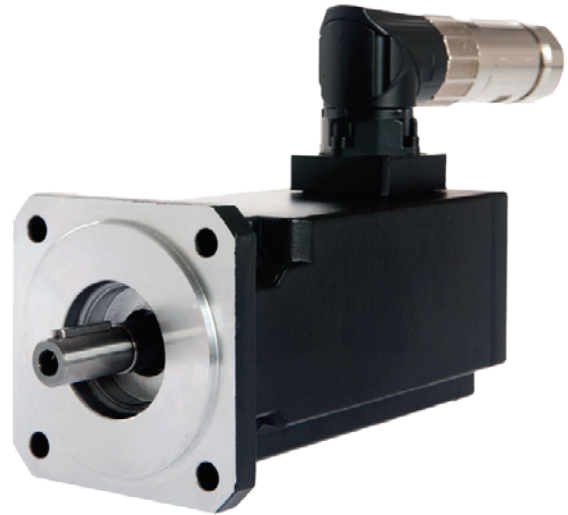

Technical Characteristics - Overview

Motor Type	Permanent magnets synchronous servomotor
Rotor Design	Rotor with surface rare earth magnets
Power Range	0.2...9.4 kW
Torque Range	0.5...60 Nm
Speed Range	0...7500 min ⁻¹
Mounting	Flange with smooth holes
Shaft End	Plain keyed shaft Plain smooth shaft (option)
Cooling	Natural ventilation
Protection Level (IEC60034-5)	IP64 IP65 (option)
Feedback sensor	Encoder Hiperface DSL® (option S5, S6)
Other options	Brake Thermal protection (PTC) Increased inertia
Marking	CE / UL
Voltage Supply	230 / 400 VAC other voltage under request
Temperature Class	Class F
Connections	Single rotatable connector





7.1.1. Order code of motor cable

	1	2	3	4	5	6	7	8
Ordering example	CBM	010	H	B	M23	PSX	0150	00
1 Cable								
CBM	Motor cable							
2 Cross-section								
007	0.75 mm ²							
015	1.5 mm ²							
025	2.5 mm ²							
040, 060, 100, 250 mm	4 mm ² , 6 mm ² , 10 mm ² , 25 mm ²							
3 Cable Type								
H	HIPERFACE DSL® highly flexible							
4 Brake wire								
0	Standard, without brake wire							
B	with brake wire							
D	With brake wire and HIPERFACE DSL®							
5 Assembly of motor side								
M15	SpeedTec M15 (for Motor connector - Order code IY)							
M23	SpeedTec M23 (for motor connector - order code IZ)							
XXX	Terminal Box							
6 Assembly of drive side								
PSX	PSD1-S							
PMX	PSD1-M							
7 Length [10 cm steps]								
0100	Length in 10 cm (max. 50 m) Example: 0025 = 2.5 m, 0205 = 20.5 m, 1020 = 102.0 m Standard length [m]: 3 / 5 / 7 / 10 / 12 / 15 / 20 / 25 / 30 / 35 / 40 / 45 / 50							
8 Special design								
00	Standard							

7.2 EMC measures

[In diesem Kapitel finden Sie](#)

• Mains filter.....	84
• Motor output chokes.....	87
• Line choke.....	89

7.2.1. Mains filter

[In diesem Kapitel finden Sie](#)

• Mains filters for PSD1-S single-phase ECP-0001-01	85
• Mains filters for PSD1-S 3-phases operation ECP-0002-01	85
• Mains filters for PSD1-M_P010 and PSD1-M_P020)	86

For radio disturbance suppression and for complying with the emission limit values for CE conform operation we offer mains filters:

Observe the maximum permitted length of the connection between the mains filter and the device:

- unshielded <0.5m;
- shielded: <5m (fully shielded on ground e.g. ground of control cabinet)





7.2.1.1 Mains filters for PSD1-S single-phase ECP-0001-01

Mains filters with UL certification for PSD1-S_1200 (2 A) and PSD1-S_1300 (5 A)

Necessary for limit value class C3 (in accordance with EN 61800-3) in single phase operation with motor cable length > 10 m

Scale drawing:

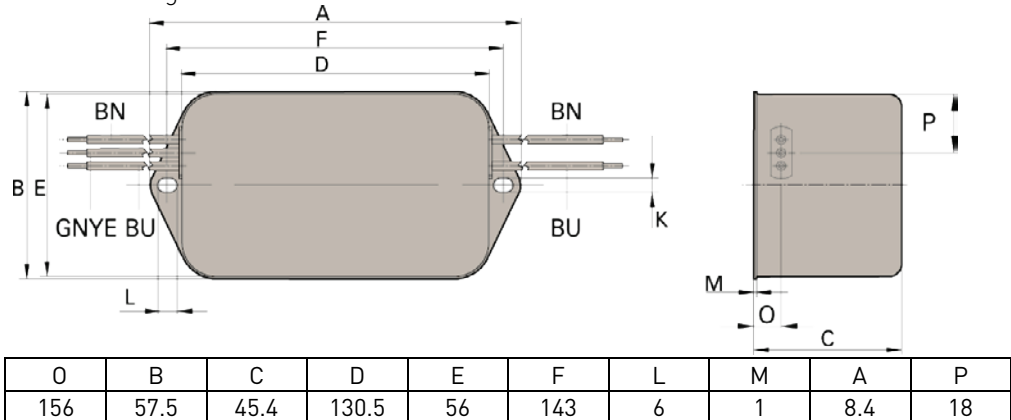

Stated in mm

Color code:

BN Brown

BU blue

GNYE green-yellow

Weight: 0.67 kg

7.2.1.2 Mains filters for PSD1-S 3-phases operation ECP-0002-01

Mains filters with UL certification for PSD1-S_1200 (2 A) and PSD1-S_1300 (5 A) for 3-phases operation

Required for limit value class C3 (In accordance with EN 61800-3) in 3-phase operation with motor cable length > 10m

Scale drawing:

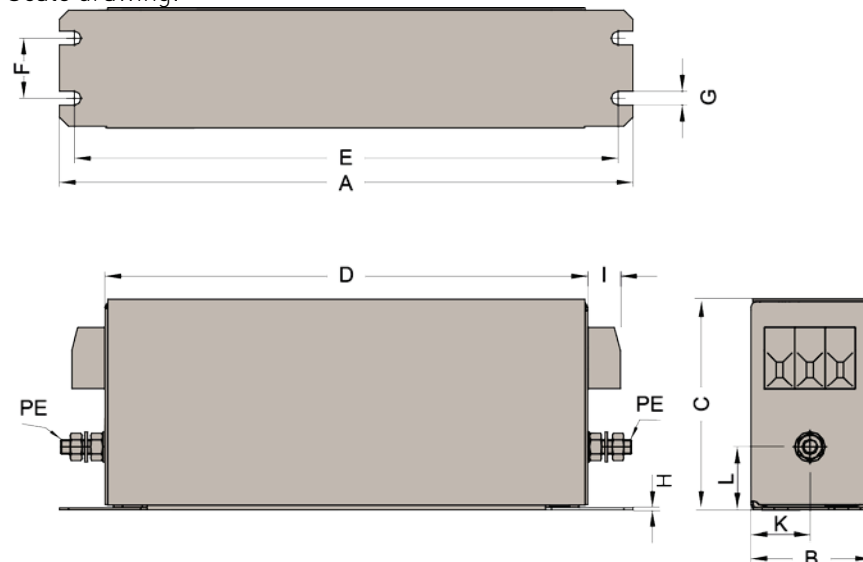



O	B	C	D	E	F	G	H	I	PE	K	L
250	45	70	220	235	25	5.4	1	22	M5	22.5	29.5

Stated in mm

Weight: 0.8 kg

Port Connections: AWG8 (10 mm² rigid, 6 mm² flexible)

tightening torque: 1.5 ... 1.8 Nm

7.2.1.3 Mains filters for PSD1-M_P010 and PSD1-M_P020)

Mains filters with UL certification

- Mains filters ECP-0003-01 for PSD1-M_P010: Axis system with motor cable > 6x 10 m
- Mains filter ECP-0003-02 for PSD1-M_P010: Axis system with motor cable > 6x 50 m
- Mains filters ECP-0003-03 for PSD1-M_P020: Axis system with motor cable > 6 x 50 m

Scale drawing:

Bottom view

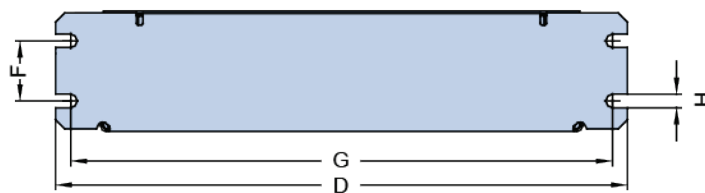

Side view

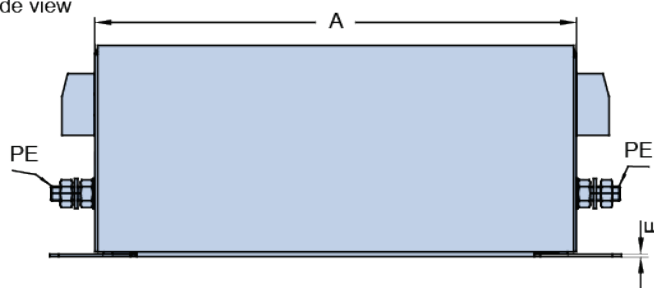

Front view

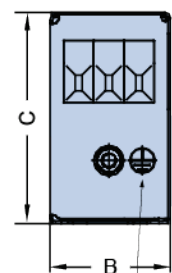

Coin Cell Earthing Symbol on both sides

Top view

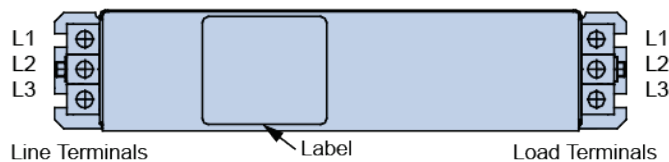

Filter type	O	B	C	D	E	F	G	H	Weight	GND(I)	Connection clamp
	mm								kg		
ECP-0003-01	240	50	85	270	0,8	30	255	5.4	1.5	M5	10mm ²
ECP-0003-02	305	60	150	335		35	320	6,4		M5	10mm ²
ECP-0003-03	220	85	90	250	1.0	60	235	5.4	2.4	M6	16 mm ²





7.2.2. Motor output chokes

In diesem Kapitel finden Sie

- Motor output chokes ECM-0005-01 for PSD1-S 87
- Output (Motor) Chokes ECM-0004-01 for PSD1-M 88
- Motor output chokes ECM-0001-01 for PSD1-M 88
- Motor output chokes ECM-0002-01 for PSD1-M 89
- Wiring of the motor output filter 89

For disturbance suppression when the motor connecting cables are long (> 50 m) we offer motor output chokes:

7.2.2.1 Motor output chokes ECM-0005-01 for PSD1-S

For motor cable length > 50m

Inductance	1 mH
Rated current	7 A
Protection class	Not defined
Ambient temperature	0 -40 °C
Max. Elevation of operating site	1000 m above sea level
Weight	2.5 kg

Up to 7 A nominal motor current (1 mH)

Scale drawing:

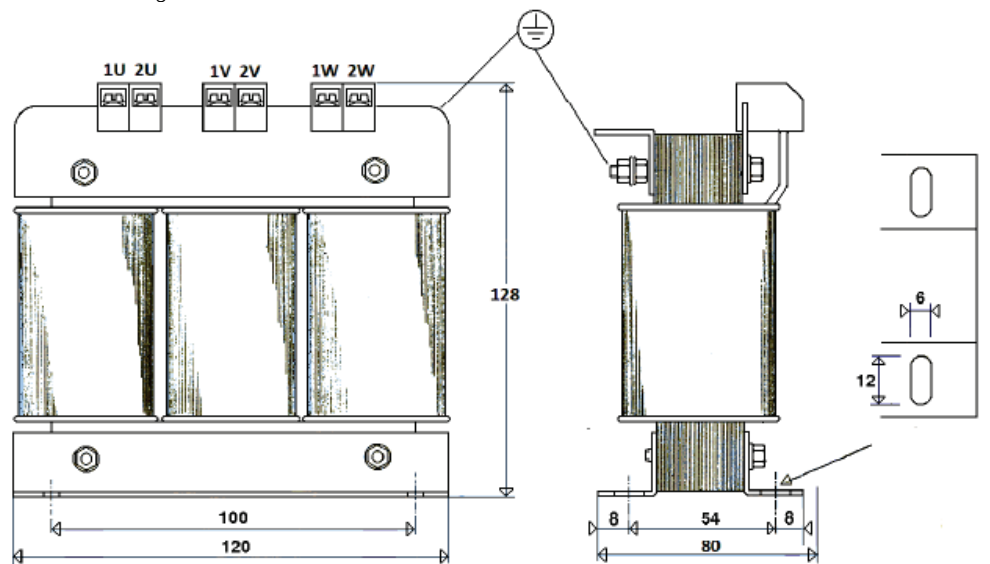

Stated in mm





7.2.2.2 Output (Motor) Chokes ECM-0004-01 for PSD1-M

For motor cable length > 20m

Inductance	3.6mH
Rated current	6.3 A
Protection class	IP00
Ambient temperature	0 -40 °C
Max. Elevation of operating site	1000 m above sea level
Weight	3.2 kg

Scale drawing:

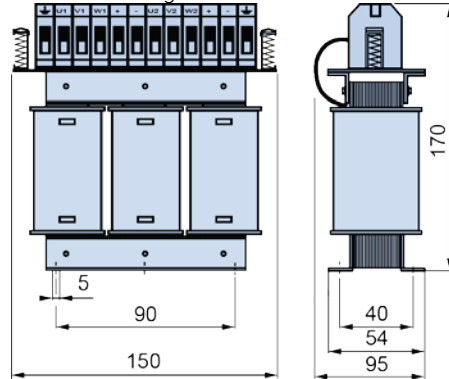

Stated in mm

7.2.2.3 Motor output chokes ECM-0001-01 for PSD1-M

For motor cable length > 20m

Inductance	2 mH
Rated current	16 A
Protection class	IP00
Ambient temperature	0 -40 °C
Max. Elevation of operating site	1000 m above sea level
Weight	4 kg

Scale drawing:

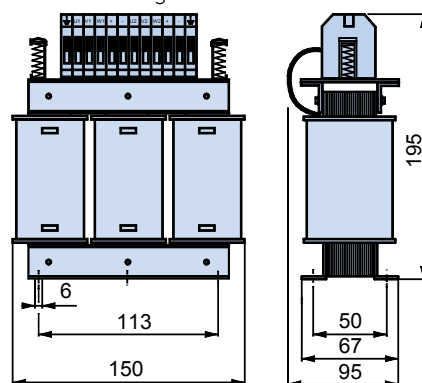

Stated in mm





7.2.2.4 Motor output chokes ECM-0002-01 for PSD1-M

For motor cable length > 20m

Inductance	1.1mH
Rated current	30 A
Protection class	IP00
Ambient temperature	0 -40 °C
Max. Elevation of operating site	1000 m above sea level
Weight	7 kg

Scale drawing:

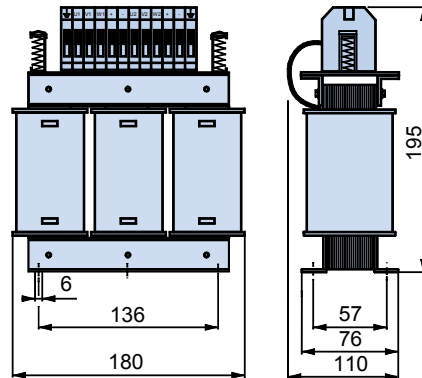

Stated in mm

7.2.2.5 Wiring of the motor output filter

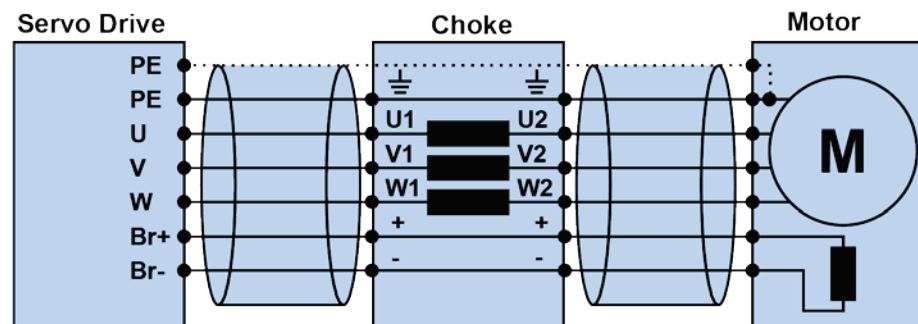



7.2.3. Line choke

In diesem Kapitel finden Sie

- Line choke for PSD1-M_P010 90
- Mains filter for PSD1-M_P020 90

7.2.3.1 Line choke for PSD1-M_P010

By means of the line choke IND-0001-02 (with UL certification) the output performance of PSD1-M_P010 can be increased by 50 %. Line chokes for reducing the low-frequency interferences on the mains side.

0.86 mH / 30 A

Scale drawing: IND-0001-02

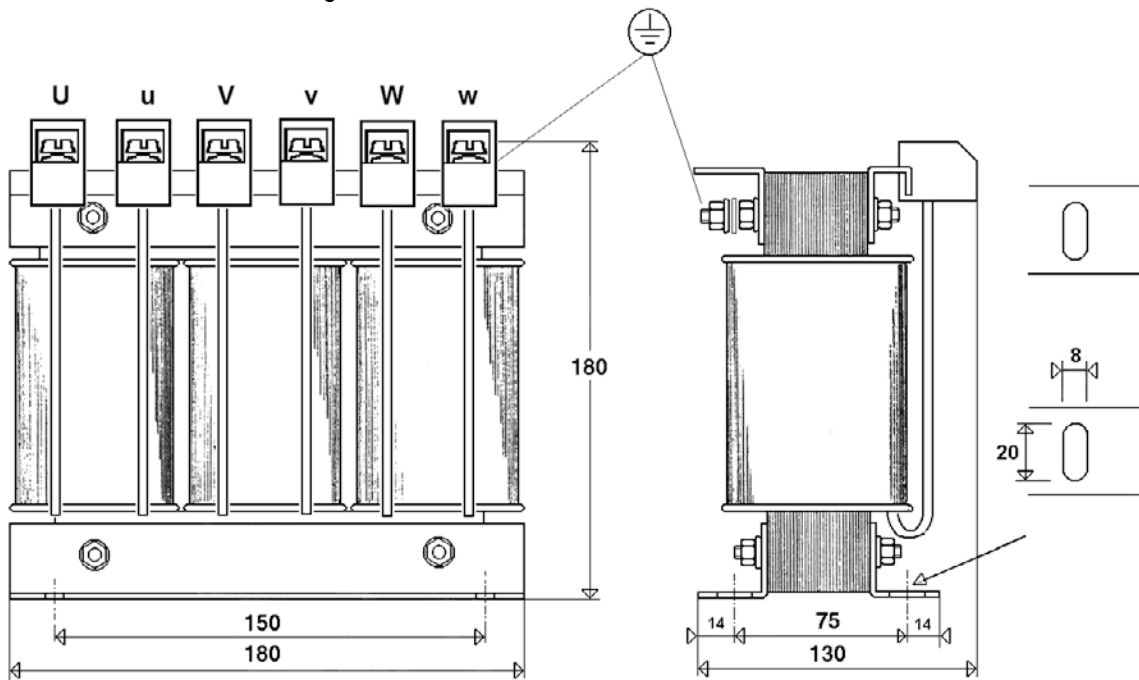

Weight: 8 kg

7.2.3.2 Mains filter for PSD1-M_P020

Line choke for PSD1_M_P020: 0.45 mH / 55 A

We offer the following line chokes:

- IND-0002-01: 0.45 mH / 55 A / 10 kg
- IND-0002-02: 0,45 mH / 55 A / 9 kg / UL

Scale drawing: IND-0002-01

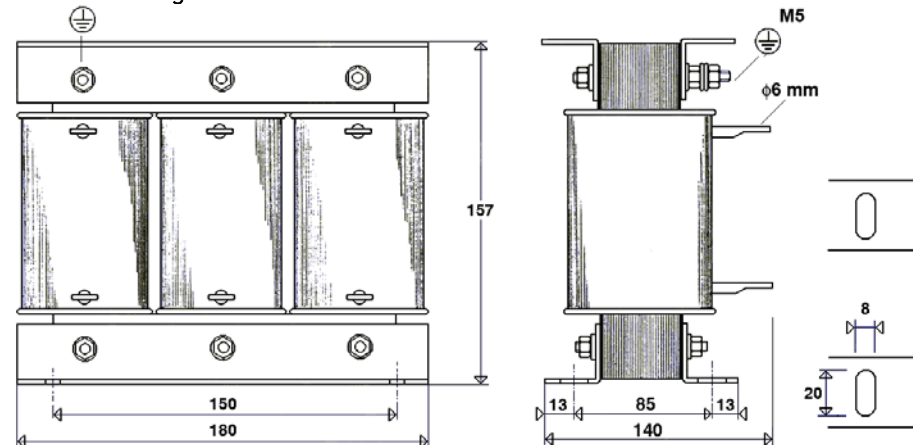



Scale drawing: IND-0002-02 (UL-Version)

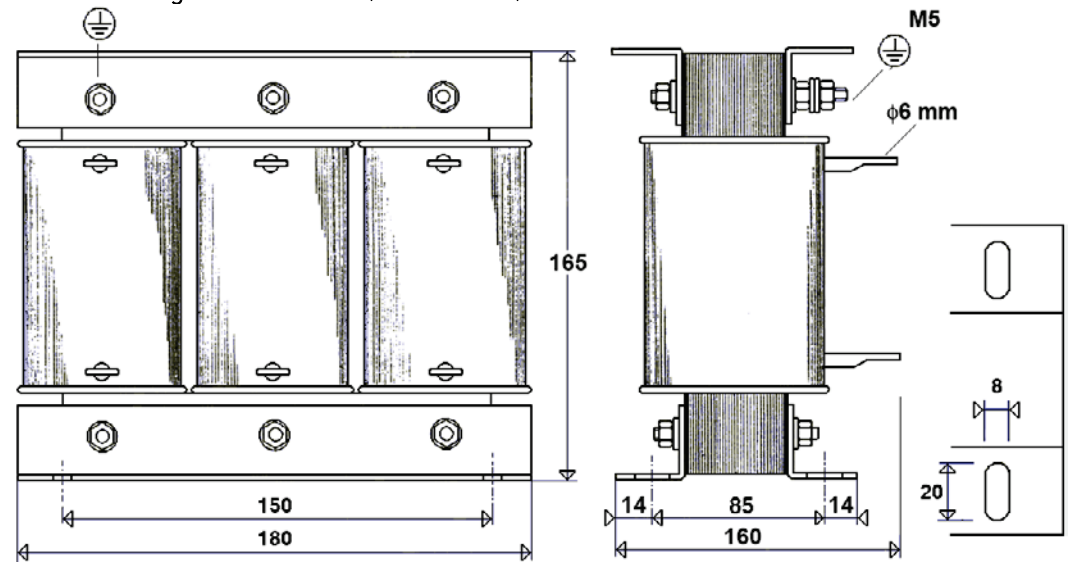

7.3 External braking resistors

In diesem Kapitel finden Sie

- Overview Braking Resistors PSD1..... 92
- Braking resistor ACB-0004-01 92
- Braking resistor ACB-0001-01 und ACB-0002-01 93
- Braking resistor ACB-0003-01 for PSD1-M_P020..... 94

DANGER

Hazards when handling ballast resistors!

Housing temperature up to 200°C!

Dangerous voltage!

The device may be operated only in the mounted state!

The external braking resistors must be installed such that protection against contact is ensured (IP20).

Install the connecting leads at the bottom.

The braking resistors must be grounded.

We recommend to use a thrust washer for the ACB-0001-01 and ACB-0002-01.

Observe the instructions on the resistors (warning plate).

Note that a length of the cable >2 m is not permitted!

WARNING

When mounting the brake resistor, please observe the expansion of the housing of max. 0.85 mm / 100 mm due to heating (mounting with fixed and floating bearings).

Mount the resistors in such a way that supply and extract air access is possible in order to avoid heat accumulation. Resistors need to be protected by respective protective measures.

The resistors with the thermal contact surface are to be mounted continuously to a flat clamping area.





7.3.1. Overview Braking Resistors PSD1

Category	Specifications		
Braking resistor (see page 91)	Device	Nominal power rating	UL certification
ACB-0004-01 (50 Ω) (see page 92)	PSD1-S_1200 / 1300	100 W	With UL
ACB-0001-01 (30 Ω) (see page 93)	PSD1-M_P010 PSD1-M_P020 with 2x30 Ω parallel	400 W	With UL
ACB-0002-01 (15 Ω) (see page 93)	PSD1-M_P010 with 2x15Ω in series PSD1-M_P020	400 W	With UL
ACB-0003-01 (15 Ω) (see page 94)	PSD1-M_P020	1500 W	Without UL

7.3.2. Braking resistor ACB-0004-01

Pulse power (W) Tu ~ 40 °C *referring to a cycle time of 120 s (reference value)	ED 6 %*	900
	ED 15 %*	500
	ED 25 %*	300
	ED 40 %*	200
Nominal continuous output (W) Ta ~ 40°C		100
Nominal resistance value at 20°C		51 Ω
Nominal tolerance at 20°C		±10%
Type of protection (EN 60529) (in the corresponding bolted state)		IP 65
Max. permitted operation voltage		UL 1000 V
Cooling		Natural convection
Housing temperature at a continuous nominal output Tu ~ 40 °C		approx. 180 °C
Electrical connection		2x AWG 14 / l=25 cm
Operating temperature range		-25 ... +40 °C
Test voltage		2.7 kV AC 1 s
Certification / Marking		UL; CSA
Weight		0.43 kg
Mounting positions		

Scale drawing:

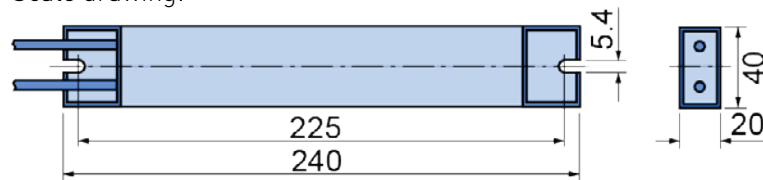

Stated in mm





7.3.3.

Braking resistor ACB-0001-01 und ACB-0002-01

Pulse power (W) Tu ~ 40 °C *referring to a cycle time of 120 s (reference value)	ED 6 %*	3600
	ED 15 %*	2000
	ED 25 %*	1200
	ED 40 %*	800
Nominal continuous output (W) Ta ~ 40 °C		400
Nominal resistance value at 20 °C		ACB-0001-01: 30 Ω ACB-0002-01: 15 Ω
Nominal tolerance at 20 °C		±10%
Type of protection (EN 60529) (in the corresponding bolted state)		IP 54
Max. permitted operation voltage		UL 600 / 1000 V
Cooling		Natural convection
Housing temperature at a continuous nominal output Tu ~ 40 °C		approx. 340 °C
Electrical connection		2x AWG 16 / l=25 cm
Operating temperature range		-25 ... +40 °C
Test voltage		2.7 kV AC 1 s
Certification / Marking		UL; CSA
Weight		1.1kg
Mounting positions		

Scale drawing:

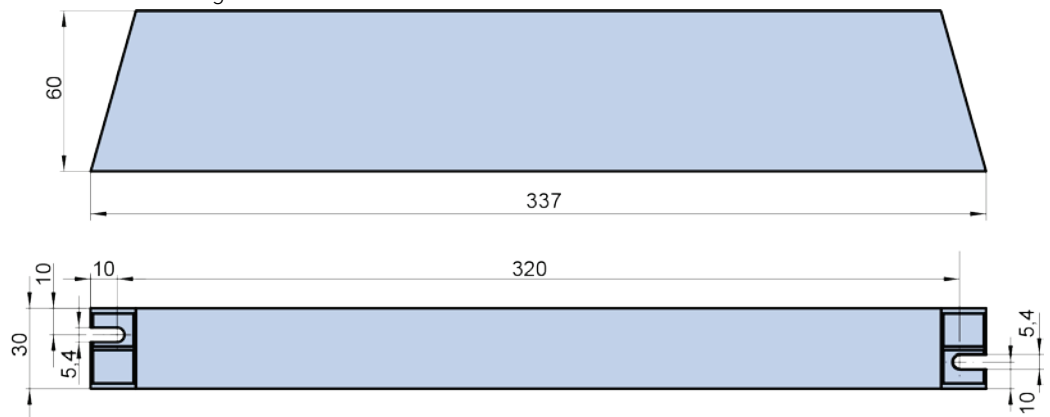

Stated in mm





7.3.4. Braking resistor ACB-0003-01 for PSD1-M_P020

Pulse power (W) $T_u \sim 40^\circ\text{C}$ *referring to a cycle time of 120 s (reference value)	ED 1%*	30.0
	ED 6%*	12.0
	ED 15%*	6.8
	ED 25%*	4.5
	ED 40%*	3.2
	ED 60%*	2.3
Nominal continuous output (W) $T_a \sim 40^\circ\text{C}$		1.5
Nominal resistance value at 20°C		$15\ \Omega$
Nominal tolerance at 20°C		$\pm 10\%$
Type of protection (EN 60529) (in the corresponding bolted state)		IP 20
Max. permitted operation voltage		600 VAC or 800 V DC
Cooling		Natural convection
Electrical connection		on the thermal current overload cut-off $2.5\ \text{mm}^2$
Operating temperature range		$+5 \dots +40^\circ\text{C}$
Test voltage		2.5 kV AC
Certification / Marking		CE
Weight		4.4 kg
Mounting positions		

Scale drawing:

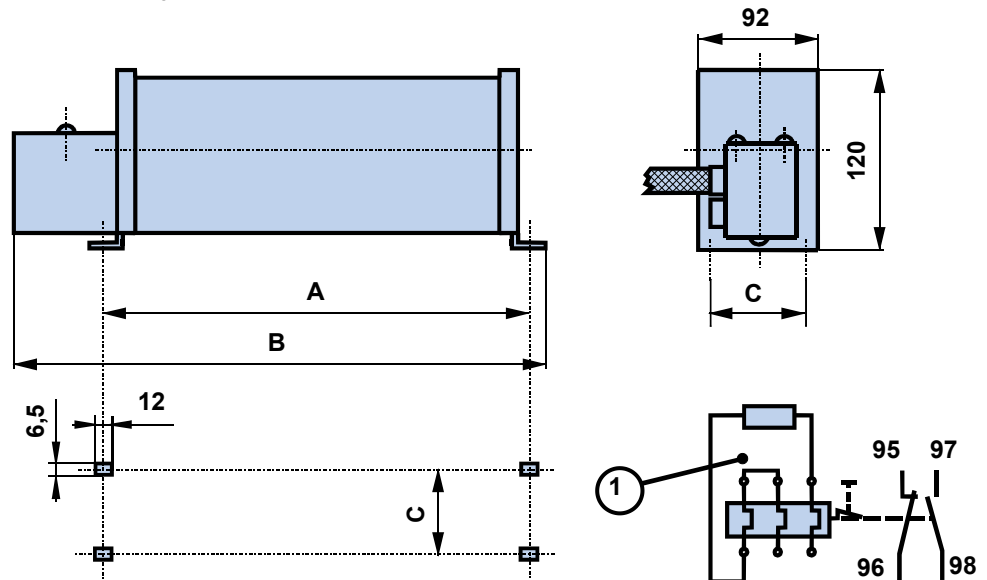

1: thermal overcurrent relay

ACB-0003-01		
O	mm	540
B	mm	620
C	mm	64





7.4 Interface Cables

7.4.1. Ethernet Cables: CBD000C0-T00-T00-xxxx-00

Ethernet - Crossover - cable Cat5e

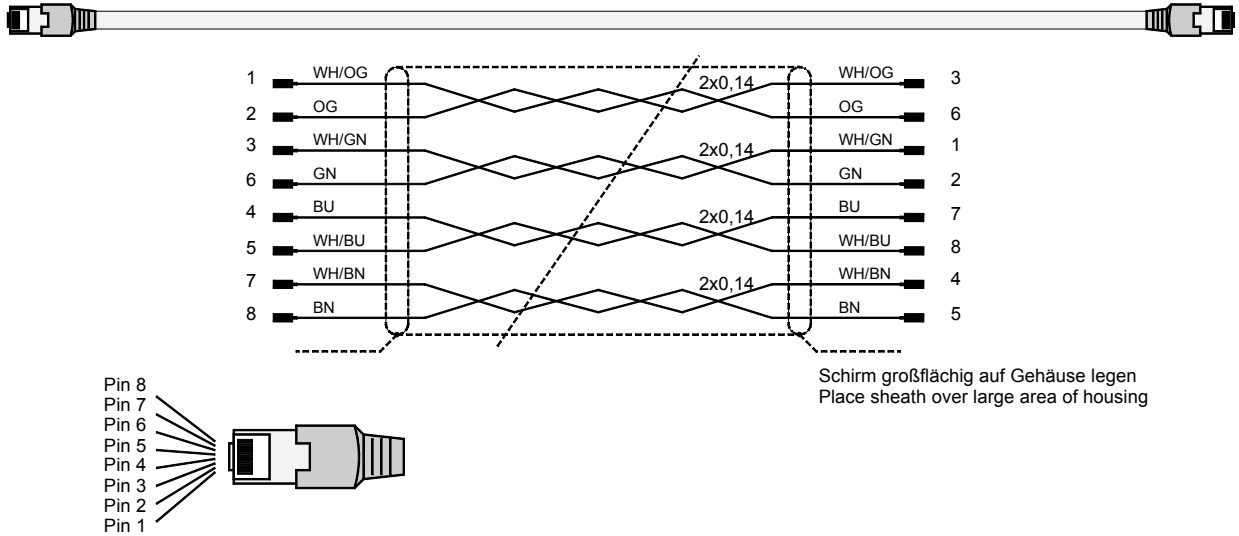

Length code des Ethernet - Crossover - cables: CBD000D0-T00-T00-xxxx-00

xxxx = Length code (Active part length in dm)

0.25 m CBD000D0-T00-T00-0002-00

0.5 m CBD000D0-T00-T00-0005-00

1 m = CBD000D0-T00-T00-0010-00





8. Technical data

In diesem Kapitel finden Sie

- PSD1-S: Single device 96
- PSD1-M: Multi-axes system..... 98
- Motor technologies supported..... 102
- Feedback system HIPERFACE DSL® 102
- Incremental encoder / analogue HAL sensor with 1VSS 102
- Motor holding brake output 102
- Digital inputs / outputs (specifications) 103
- Technical data STO 103
- EC directives and applied harmonized EC norms (PSD1)..... 104
- EMC limit values PSD1..... 104
- Insulation requirements PSD1 104
- Environmental requirements PSD1 104
- cUL certification..... 105
- EtherCAT characteristics 105
- PROFINET Characteristics..... 105
- EtherNet/IP - Kenndaten..... 106

8.1 PSD1-S: Single device

In diesem Kapitel finden Sie

- Mains connection PSD1-S..... 96
- Output data PSD1-S 1/3*230 VAC..... 97
- Control Voltage 24 VDC PSD1-S..... 97
- Braking operation PSD1-S..... 97
- Baugröße / Gewicht PSD1-S..... 97

8.1.1. Mains connection PSD1-S

Category	Specifications	
PSD1-S	PSD1-S_1200	PSD1-S_1300
Mains voltage	3 phases 3* 230 VAC ±10% 30 ... 253 VAC / 50-60 Hz or Single Phase 230 VAC ±10% 30 ... 253 VAC / 50-60 Hz	
Input Current	(1AC230V): 6.8 Arms 3AC230V: 1.7 Arms	(1AC230V): 11 Arms 3AC230V: 4.2 Arms
Maximum fuse per device*	Single phase: 8 A Three phases: 3 A Fuse Class: gS (gRL), Time-delay	Single phase: 12 A Three phases: 6 A Fuse Class: gS (gRL), Time-delay
Earth leakage current	Current on the mains PE (see page 27) (>3,5 mA)	
Supply networks	Possible supply networks (see page 27): TN	

* Circuit breakers for operation according to CE.
 Circuit breakers for UL und CSA see **UL Chapter** (see page 20, see page 24).



**8.1.2. Output data PSD1-S 1/3*230 VAC**

Category	Specifications	
Device type	PSD1-S_1200 (2 A)	PSD1-S_1300 (5 A)
Output voltage	3 x 0 ... 230 V ±10 %	
Output nominal current (I _n)	2 A _{rms}	5 A _{rms}
Pulse current for 2 s	6 A _{rms}	15 A _{rms}
Power at continuous operation	0.64 kW (3-phases mains supply) 0.64 kW (1-phase mains supply)	1.1 kW (3-phases mains supply) 1.1 kW (1-phase mains supply)
Switching frequency of the motor current	8 kHz	8 kHz
Heat dissipation for I _n	13 W	35 W

8.1.3. Control Voltage 24 VDC PSD1-S

Category	Specifications
Voltage operating range	21 - 27 VDC
Ripple	0.5 V _{ss}
Requirement according to safe extra low voltage (SELV)	yes (class 2 mains module)
Electric current drain	0.5 A + Output current of digital output currents (fed via connectors X17/2, 3) + Output current of motor brakes (fed via connectors X51/1 & 2)) + Current requirements of optional boards

8.1.4. Braking operation PSD1-S

Category	Specifications	
Controller type	PSD1-S_1200 (2 A)	PSD1-S_1300 (5 A)
Capacity/ storable energy	760 µF / 15 Ws	1140 µF / 23 Ws
Minimum braking resistance	51 Ω	51 Ω
Maximum continuous current	7.85 A	7.85 A

External ballast resistors from Parker (see page 92).

Data of the integrated dynamic brake module PSD1-S

Category	Specifications			
Mains module	Maximum current		Max. Duty Cycle	Minimum resistance value
	Peak	Duration		
PSD1-SW1200 PSD1-SW1300	7.84 A	0.1 A	1.27% @ 60 s	51 Ω (40W)

8.1.5. Baugröße / Gewicht PSD1-S

Kategorie	Spezifikation	
Reglertyp	Gewicht [kg]	Abmessungen Höhe x Breite x Tiefe [mm]
PSD1-S_1200 PSD1-S_1300	1,33	200 x 50 x 180





8.2 PSD1-M: Multi-axes system

In diesem Kapitel finden Sie

- Mains Connection Power module PSD1-M_P010 with line choke 98
- Mains connection Power module PSD1-M_P010 with line choke 98
- Mains Connection Power module PSD1-M_P020 without line choke 99
- Mains connection Power module PSD1-M_P020 with line choke 99
- Output data servo modules PSD1-M 3*400 VAC 100
- Output data of power output stage at PSD1-M with 3*400 VAC power supply of the mains modules 100
- Control voltage 24 VDC PSD1-M_P (mains module) 100
- Braking operation PSD1-M 101
- Dynamic braking module 101
- Size / Weight PSD1-M 101

8.2.1. Mains Connection Power module PSD1-M_P010 with line choke

Category	Specifications		
PSD1-M_P010	230 V	400 V	480 V
Mains voltage	230 VAC ±10 % 50-60 Hz	400 VAC ±10 % 50-60 Hz	480VAC ±10% 50-60Hz
Rated voltage	3 AC 230 V	3 AC 400 V	3 AC 480 V
Input Current	22 Arms	22 Arms	18 Arms
Output voltage	325 VDC ±10 %	565 VDC ±10 %	680 VDC ±10 %
Output power	6 kW	10 kW	10 kW
Pulse power (<5 s)	12 kW	20 kW	20 kW
Power dissipation	60 W	60 W	60 W
Maximum fuse rating per device	Measure for line and device protection: UL listing (DIVQ) fuses Manufacturer: ABB, Stotz-Kontakt GmbH (E212323) Model No.: S203UP-K, 1 fuse 480 VAC, 3-phase, 25 A, operating temperature 55 °C		

8.2.2. Mains connection Power module PSD1-M_P010 with line choke

Increased power by means of a line choke (see page 90)

Category	Specifications		
PSD1-M_P010 with line choke	230 V	400 V	480 V
Mains voltage	230 VAC ±10 % 50-60 Hz	400 VAC ±10 % 50-60 Hz	480VAC ±10% 50-60Hz
Rated voltage	3 AC 230 V	3 AC 400 V	3 AC 480 V
Input Current	24.5 A	24.5 A	20.4 A
Output voltage	325 VDC ±10 %	565 VDC ±10 %	680 VDC ±10 %
Output power	9 kW	15 kW	15 kW
Pulse power (<5 s)	18 kW	30 kW	30 kW
Power dissipation	70 W	70 W	70 W
Maximum fuse rating per device	Measure for line and device protection: UL listing (DIVQ) fuses Manufacturer: ABB, Stotz-Kontakt GmbH (E212323) Model No.: S203UP-K, 1 fuse 480 VAC, 3-phase, 25 A, operating temperature 55 °C		
Earth leakage current	Current on the mains PE (see page 27) (>3,5 mA)		
Supply networks	Possible supply networks (see page 27): TN		



WARNING

The specified performance data are only valid in connection with line choke IND-0001-02 (see page 90).



**8.2.3. Mains Connection Power module PSD1-M_P020 without line choke**

Category	Specifications		
	230 V	400 V	480 V
PSD1-M_P020			
Mains voltage	230 VAC ±10 % 50-60 Hz	400 VAC ±10 % 50-60 Hz	480VAC ±10% 50-60Hz
Rated voltage	3 AC 230 V	3 AC 400 V	3 AC 480 V
Input Current	44 Arms	44 Arms	35 Arms
Output voltage	325 VDC ±10 %	565 VDC ±10 %	680 VDC ±10 %
Output power	12 kW	20 kW	20 kW
Pulse power (<5 s)	24 kW	40 kW	40 kW
Power dissipation	120 W	120 W	120 W

Maximum fuse rating per device 2 special purpose fuses in line are required	Cable protection measure: MCB (K characteristic) with a rating of 50A / 4xxVAC (depending on the input voltage) Recommendation: (ABB) S203U-K50 (440VAC)
	Device protection measure: Circuit breakers 80A / 700VAC per supply leg in accordance with UL category JFHR2 Requirement: Bussmann 170M1366 or 170M1566D

8.2.4. Mains connection Power module PSD1-M_P020 with line choke

Increased power by means of a line choke (see page 90)

Category	Specifications		
	230 V	400 V	480 V
PSD1-M_P020 with line choke			
Mains voltage	230 VAC ±10 % 50-60 Hz	400 VAC ±10 % 50-60 Hz	480VAC ±10% 50-60Hz
Rated voltage	3 AC 230 V	3 AC 400 V	3 AC 480 V
Input Current [rms]	44 A	44 A	40 A
Output voltage	325 VDC ±10 %	565 VDC ±10 %	680 VDC ±10 %
Output power	15.5 kW	27 kW	30 kW
Pulse power (<5 s)	31 kW	54 kW	60 kW
Power dissipation	140 W	140 W	140 W

Maximum fuse rating per device 2 special purpose fuses in line are required	Cable protection measure: MCB (K characteristic) with a rating of 50A / 4xxVAC (depending on the input voltage) Recommendation: (ABB) S203U-K50 (440VAC)
	Device protection measure: Circuit breakers 80A / 700VAC per supply leg in accordance with UL category JFHR2 Requirement: Bussmann 170M1366 or 170M1566D
Earth leakage current	Current on the mains PE (see page 27) (>3,5 mA)
Supply networks	Possible supply networks (see page 27): TN

**WARNING**

The specified performance data are only valid in connection with line choke (see page 90) IND-0002-01 or IND-0002-02 (UL).





8.2.5. Output data servo modules PSD1-M 3*400 VAC

Category	Specifications			
	Controller type	Number of power output stage	Rated Output Current [A _{rms}]	Pulse current for 2 s [A _{rms}]
PSD1-M_1300		1	5	10
PSD1-M_1400		1	8	16
PSD1-M_1600		1	15	30
PSD1-M_1800		1	30	60
PSD1-M_2220		2	2 + 2	4 + 4
PSD1-M_2330		2	5 + 5	10 + 10
PSD1-M_2440		2	8 + 8	16 + 16
PSD1-M_2630		2	15 + 5 *	30 + 10
PSD1-M_3222		3	2 + 2 + 2	4 + 4 + 4
PSD1-M_3433		3	8 + 5 + 5 *	16 + 10 + 10

* Maximum sum current per device: 16 A.

8.2.6. Output data of power output stage at PSD1-M with 3*400 VAC power supply of the mains modules

Category	Specifications				
	2 A	5 A	8 A	15 A	30 A
Device type					
Input voltage	300 ... 750 VDC				
Output voltage	3x 0-400 V (0...450 Hz)				
Output nominal current	2 A _{rms}	5 A _{rms}	8 A _{rms}	15 A _{rms}	30 A _{rms}
Pulse current for 2 s	4 A _{rms}	10 A _{rms}	16 A _{rms}	30 A _{rms}	60 A _{rms}
Power at continuous operation	1.2 kVA	3 kVA	4.8 kVA	9 kVA	18 kVA
Switching frequency of power output stage	8 kHz	8 kHz	8 kHz	4 kHz	4 kHz
Heat dissipation for In	20 W	45 W	75 W	105 W	220 W

8.2.7. Control voltage 24 VDC PSD1-M_P (mains module)

Category	Specifications
Voltage operating range	21 - 27 VDC
Ripple	0.5 V _{ss}
Requirement according to safe extra low voltage (SELV)	yes
Electric current drain	PSD1-M_P010: 0.2 A PSD1-M_P020: 0.3 A ea. PSD1-M Axis: 1.0 A + Output current of digital output currents (fed via connectors X17/2, 3) + Output current of motor brakes (fed via connectors X46/7 & 8; PSD1M_1800 X44/3 & 4) + Current requirements of optional boards





8.2.8. Braking operation PSD1-M

Mains modules

Category	Specifications	
Device type	PSD1-M_P010	PSD1-M_P020
Capacity/ storable energy	550 μ F/ 92 Ws at 400 V 53 Ws at 480 V	1175 μ F/ 197 Ws at 400 V 114 Ws at 480 V

Servo Drives

Category	Specifications		
Controller type	PSD1-M_1600 (15 A)	PSD1-M_3433 (8A/5A/5A)	PSD1-M_1800 (30 A)
Capacity / storable energy (± 20 %)	220 μ F / 37 Ws at 400 V 21 Ws at 480 V	220 μ F / 37 Ws at 400 V 21 Ws at 480 V	440 μ F / 74 Ws at 400 V 42 Ws at 480 V

8.2.9. Dynamic braking module

Data of the integrated dynamic brake module PSD1-M_P

Category	Specifications			
	Maximum current		Max. Duty Cycle	Minimum resistance value
Mains module	Peak	Duration		
PSD1-M_P010	28.8 A	4.27 A (500 W)	2.2 % (@60 s)	27 Ω
		7.5 A (1500 W)	6.7 % (@60 s)	
PSD1-M_P020	78.0 A	7.06 A (500 W)	0.82 % (@60 s)	10 Ω
		22.3 A (5000 W)	8.2 % (@60 s)	

Recommended braking resistors

Category	Specifications	
Mains module	Minimum resistance value	Power
PSD1-M_P010	27 Ω	500 W ... 1500 W
PSD1-M_P020	10 Ω	500 W ... 5000 W

External ballast resistors from Parker (see page 92).

8.2.10. Size / Weight PSD1-M

Category	Specifications	
Controller type	Weight [kg]	Dimensions Height x Width x Depth (mm)
PSD1-M_1300	4	360 x 50 x 270
PSD1-M_1500		
PSD1-M_1600		
PSD1-M_P010		
PSD1-M_2220		
PSD1-M_2330	4	360 x 50 x 270
PSD1-M_2440		
PSD1-M_2630		
PSD1-M_3222	4.2	360 x 100 x 270
PSD1-M_3433		
PSD1-M_1800	6.8	360 x 100 x 270
PSD1-M_P020	6,3	

Mounting (see page 41, see page 42, see page 31)





8.3 Motor technologies supported

Category	Specifications
Motors Direct drives <ul style="list-style-type: none"> • Linear motors • Torque motors 	<ul style="list-style-type: none"> • Sinusoidally commutated synchronous motors <ul style="list-style-type: none"> ◆ Maximum rotating field frequency: 590 Hz* ◆ General max. speed: 60*590/number of pole pairs in [min⁻¹]. ◆ Maximum number of poles = 1200 • Temperature sensor: KTY84-130(insulated in accordance with EN60664-1 or IEC60664-1) • 3 phase synchronous direct drives

8.4 Feedback system HIPERFACE DSL®

	Single Turn	Multiturn
Order Number	ENCODERS5	ENCODERS6
Resolution	18 Bit	18 Bit
Measurement steps per revolution	262144	262144
Captured revolutions	1	4096
Integral non-linearity	± 80 "	± 80 "
Differential non-linearity	± 40 "	± 40 "
Maximum speed	12000 min ⁻¹	9000 min ⁻¹
Rotor moment of inertia	450 gmm ²	450 gmm ²
Operating Temperature	-20 .. +105 °C	-20 .. +105 °C
Protection class	IP40	IP40
Safety technology (IEC 61508 – EN ISO 13849)	SIL2; PL d	SIL2; PL d

8.5 Incremental encoder / analogue HAL sensor with 1VSS

Category	Specifications
Sinus-Cosinus Encoder / analogue Hall sensor (see page 51) *	<ul style="list-style-type: none"> • Linear or rotary • Sin/Cos signal: max. 5 VSS; typical 1 VSS; 90° offset • Max. 200 kHz

* in the first stage only for PSD1MV1...: Multi axes device with one powerstage.

8.6 Motor holding brake output

Category	Specifications
Voltage operating range	21 ... 27 VDC
Maximum output current (short circuit proof)	PSD1-S: 1.0 A PSD1-M: 1.6 A





8.7 Digital inputs / outputs (specifications)

Category	Specifications
Digital inputs	<ul style="list-style-type: none"> • 4 Digital inputs • Input resistor 22 kΩ All inputs and outputs do have 24 V level. Input level: "0" (low) = Rated Input Voltage \leq 12.5 V "1" (high) = Rated Input Voltage \geq 13.5 V
Digital outputs	<ul style="list-style-type: none"> • 2 Digital outputs (4 on mains module) • Load max. 100 mA

8.8 Technical data STO

Category	Specifications	
STO Certificate (http://www.Parker.com/Literature/Electromechanical/Europe/Certificates/DOC-0014-01_PSD_STO_Certificate.pdf)	According to EN ISO13849 Device certified if "STO certified" is stated in type plate (below the CE sign)	 <p>PSD1 IEC 61508:2010 SIL 3 EN 61800-5-2:2007 SIL 3 ISO 13849-1:2015 PL e ISO 13849-2:2012</p> <p>SEBS-A.162311/13</p>
Nominal voltage of the inputs	24 VDC	
Required isolation of the 24V control voltage	Grounded protective extra low voltage, PELV	
Fuse protection	Protection of the STO control voltage: 1 A	
Number of inputs Signal inputs via optocoupler	2 Low = 0 ... 5 V DC or open High = 15 ... 26.4 VDC I_{in} at 24 VDC: 9 mA +/- 1 mA	
STO Input A, Level	Low or open = STO activated High = STO deactivated Reaction time max. 5 ms	
STO Input B, Level	Low or open = STO activated High = STO deactivated Reaction time max. 5 ms	
Switch-off time	Switch-off time with unequal input statuses: 10 s (max. error reaction time)	
Maximum tolerable test pulse time	Maximum tolerable test pulse time (low active) for external safety control: 1 ms	
Grouping of safety level	<ul style="list-style-type: none"> • Category 3 • PL=e • SIL 3 • PFHd=1.00E-9 per STO circuit • Mission time: 20 years • MTTFd = 800 years (when using EN ISO 13849-1 the MTTFd value must be limited to 100 years) 	





8.9 EC directives and applied harmonized EC norms (PSD1)

Category	Specifications
EU Low Voltage Directive 2014/35/EU	EN 61800-5-1 , Standard for electric power drives with settable speed; requirements to electric safety EN 60664-1 , isolation coordinates for electrical equipment in low-voltage systems EN 60204-1, machinery norm partly applied
EC-EMC directive 2014/30/EU	EN 61800-3, EMC standard Product standard for variable speed drives

8.10 EMC limit values PSD1

Category	Specifications
EMC interference emission	Limit values in accordance with EN 61 800-3, Limit value class C3 with mains filter.
EMC disturbances	Industrial area limit values in accordance with EN 61 800-3

8.11 Insulation requirements PSD1

Category	Specifications
Protection class	Protection class in accordance with EN 60664-1
Protection against human contact with dangerous voltages	In accordance with EN 61800-5-1
Overvoltage Category	Voltage category III in accordance with EN 60664-1

8.12 Environmental requirements PSD1

Category	Specifications
General ambient conditions	In accordance with EN 60 721-3-1 to 3-3 Climate (temperature/humidity/barometric pressure): Class 3K3
Permissible ambient temperatures:	Operation 0 to +40 °C Class 3K3 Storage -25 to +70 °C Transport -25 to +70 °C
Tolerated humidity:	Operation <= 85% Class 3K3 Storage <= 95 % Transport <= 95 % (Relative humidity)
Elevation of operating site	<=1000m above sea level for 100% load ratings <=2000m above sea level for 1% / 100m power reduction please inquire for greater elevations
Sealing	Type of protection IP20 according to EN 60 529
Mechanic resonances:	Class 2M3, 20m/s ² ;8-200Hz
Pollution Degree	Degree of contamination 2 in accordance with EN 60664-1 and EN 61800-5-1





8.13 cUL certification

Category	Specifications
PSD1M:	UL508C, 3rd Edition, power supply load revision November 9th, 2010. C22.2 N°.274-13, 12th Edition, last revision March 2013.
PSD1S:	UL61800-5-1 1st Edition, issued June, 8th, 2012 C22.2 No.274-13, 1st Edition, issued March, 2013
Certified	E-File_No.: E235342 The cUL approval is documented by a “UL” logo on the device (type specification plate). 

8.14 EtherCAT characteristics

Category	Specifications
Profile	Motion Control CiADS402
Baud rate	100 Mbits (FastEthernet)
Service data object	SDO
Cycle Time	>=1 ms
Synchronicity accuracy	maximum jitter: +/-25µs

8.15 PROFINET Characteristics

Category	Specifications
Profile	<ul style="list-style-type: none"> PROFIdrive profile drive technology V4.2
PROFINET Version	<ul style="list-style-type: none"> PROFINET IO (RT)
Transmission mode	<ul style="list-style-type: none"> 100BASE-TX (Full Duplex)
Profinet ID	<ul style="list-style-type: none"> PSD1-S: 0x5331 PSD1-M: 0x4D78
Device master file	<ul style="list-style-type: none"> PSD1-S http://www.Parker.com/Literature/Electromechanical/Europe/Downloads/GSDML-V2.3-Parker-PSD1S.zip PSD1-M http://www.Parker.com/Literature/Electromechanical/Europe/Downloads/GSDML-V2.3-Parker-PSD1M.zip
Realized application class	<ul style="list-style-type: none"> AC 3 Positioning





8.16 EtherNet/IP - Kenndaten

Kategorie	Spezifikation
Profil	DS402
Ethernet/IP	<ul style="list-style-type: none"> • Generische Geräteunterstützung für CIP und Encapsulated Layer
Ethernet	<ul style="list-style-type: none"> • Mehrere Ethernet-Schnittstellen werden unterstützt, z. B. für Geräte mit Embedded-Switch-Technologie (zur Unterstützung von Linear- oder Ringtopologie)
Verbindungsart	<ul style="list-style-type: none"> • Device Level Ring (DLR)-Funktionalität wird unterstützt (announce-basierter Ring-Knoten)
Verbindungen	<ul style="list-style-type: none"> • Unterstützung für bis zu 10 gleichzeitigen I/O-Verbindungen • Unterstützung für bis zu 10 gleichzeitigen Encapsulation Sessions • Unterstützung von bis zu 2 gleichzeitigen Explicit Messaging-Verbindungen pro Encapsulation Session • Unconnected Explicit Messaging wird unterstützt
Dienste	<ul style="list-style-type: none"> • Quality of Service (QoS) unterstützt • UDP für die Befehle ListServices, ListTargets und ListIdentity für Kapselungsprotokolle verfügbar • Pv4 Address Conflict Detection für EtherNet/IP-Geräte
Gerätestammdateien	<ul style="list-style-type: none"> • PSD1-S • PSD1-M
Produktcode	<ul style="list-style-type: none"> • PSD1-S: 21297 (0x5331) • PSD1-M: 19832 (0x4D78)
Vendorcode	<ul style="list-style-type: none"> • 4
Realisierte Objekt Klassen	<ul style="list-style-type: none"> • Identity • Message Router • Assembly • Connection Manager • Device Level Ring • QoS • PSD1 Object-Pool • TCP/IP Interface • Ethernet Link





9. Index

A

- Accessories • 17, 82
- Advantages of using the • 68
- Anzugsmoment • 21
- Applications in accordance with the Regulations • 67
- Auxiliary connection – electrical ratings • 26

B

- Baugröße / Gewicht PSD1-S • 97
- Before commissioning the drive, please observe the following: • 28, 30, 41
- Braking operation PSD1-M • 101
- Braking operation PSD1-S • 37, 97
- Braking resistor ACB-0001-01 und ACB-0002-01 • 93
- Braking resistor ACB-0003-01 for PSD1-M_P020 • 94
- Braking resistor ACB-0004-01 • 92

C

- Cable installation: • 16
- Calculation of the total failure probability • 77, 78
- Cautionary Markings • 14
- CE declaration of conformity PSD1-M • 18
- CE declaration of conformity PSD1-S • 19
- Circuit Diagram • 75, 77
- Communication interfaces • 39, 65
- Conditions of utilization • 15
- Conditions of utilization for CE-conform operation • 15
- Conditions of utilization for CSA certification • 23
- Conditions of utilization for the cUL certification of PSD1-M • 20
- Conditions of utilization for the cUL certification of PSD1-S • 24
- Conditions of utilization for the STO function • 73
- Connections of the axis system • 59
- Connector overview PSD1-M • 44
- Connector overview PSD1-M_P (Mains module) • 55
- Connector overview PSD1-S • 32
- Control requirements • 17
- Control voltage 24 VDC PSD1-M_P (mains module) • 100

- Control Voltage 24 VDC PSD1-S • 35, 97
- CSA-Zulassung • 23
- cUL certification • 105
- Current on the mains PE (leakage current) • 27

D

- Data of integrated dynamic brake unit • 26
- Description • 76
- Design Features • 76, 78
- Designated use • 10
- Device assignment • 7
- Digital inputs / outputs (specifications) • 103
- Dynamic braking module • 101

E

- EC directives and applied harmonized EC norms (PSD1) • 104
- EMC limit values PSD1 • 104
- EMC measures • 84
- Environmental requirements PSD1 • 104
- EtherCAT characteristics • 105
- Ethernet Cables
 - CBD000C0-T00-T00-xxxx-00 • 95
- EtherNet/IP - Kenndaten • 106
- Explanation of the safety instructions • 12
- External braking resistors • 91

F

- Feedback system HIPERFACE DSL® • 102
- For Safety Use • 12
- Front view (PSD1-M_P Mains Module) • 55
- Front view (PSD1-S) • 32, 44
- Functional description • 76, 78

G

- General Description • 66
- General hazards • 12
- Grounding requirements • 17

I

- Important Technical Terms and Explanations • 66
- In- / Output Ratings • 26
- Incremental encoder / analogue HAL sensor with 1VSS • 102
- Installation of the individual drive PSD1-S • 30
- Installation of the multi-axis system PSD1-M • 40
- Installations- & Environmental Characteristics PSD1-M • 20





Installations- & Environmental Characteristics
 PSD1-S • 24
 Installations- & Umgebungsbedingungen • 20,
 24
 Insulation requirements PSD1 • 104
 Interface Cables • 95
 Introduction • 7

L

Line choke • 90
 Line choke for PSD1-M_P010 • 90

M

Mains connection Power module
 PSD1-M_P010 with line choke • 62, 98
 Mains Connection Power module
 PSD1-M_P010 with line choke • 61, 98
 Mains connection Power module
 PSD1-M_P020 with line choke • 63, 99
 Mains Connection Power module
 PSD1-M_P020 without line choke • 62, 99
 Mains connection PSD1-S • 37, 96
 Mains filter • 84
 Mains filter for PSD1-M_P020 • 90
 Mains filter for use in industrial areas • 15
 Mains filters for PSD1-M_P010 and
 PSD1-M_P020) • 86
 Mains filters for PSD1-S 3-phases operation
 ECP-0002-01 • 85
 Mains filters for PSD1-S single-phase
 ECP-0001-01 • 85
 Mains module PSD1-M_P • 55
 Motor and feedback cable requirements • 16
 Motor connection / Output data • 52
 Motor holding brake output • 102
 Motor output chokes • 87
 Motor output chokes ECM-0001-01 for PSD1-M
 • 88
 Motor output chokes ECM-0002-01 for PSD1-M
 • 89
 Motor output chokes ECM-0005-01 for PSD1-S
 • 87
 Motor technologies supported • 102
 Motors • 16
 Mounting and dimensions • 30, 41
 Mounting and dimensions PSD1-M size 1 • 42
 Mounting and dimensions PSD1-M size 2 • 43
 Mounting and dimensions PSD1-S • 31

N

Notes on the STO function • 72
 Notes on the use in domestic environments •
 17

O

Order code of motor cable • 84
 Order/ type code PSD • 9
 Output (Motor) Chokes ECM-0004-01 for
 PSD1-M • 88
 Output data of power output stage at PSD1-M
 with 3*400 VAC power supply of the mains
 modules • 52, 100
 Output data PSD1-S 1/3*230 VAC • 38, 97
 Output data servo modules PSD1-M 3*400 VAC
 • 52, 100
 Overview Braking Resistors PSD1 • 92

P

P1
 Status - LEDs - indication (Mains module) • 58
 P14
 Status LED (PSD1-S) • 34
 P14 ... P16
 Status LEDs of the individual axes (PSD1-M) •
 48
 Packaging, transport, storage • 10
 PROFINET Characteristics • 105
 PROFINET connection • 39
 Protective earth • 16
 PSD
 PSD -Parker Servo Drive - Overview • 29
 PSD1-M
 Multi-axes system • 98
 PSD1-M Installations- & Environmental
 Characteristics • 21
 PSD1-S
 Single device • 96

R

Responsibility • 14

S

S2
 Modes switch (Power module) • 59
 S3
 Voltage switch (Power Module) • 59
 Safe Torque Off (STO) with PSD1 • 66
 Scope of delivery • 7
 Size / Weight PSD1-M • 101
 SMH Servo Motors with HIPERFACE DSL® -
 Feedback • 83
 Special dangers • 13
 STO and SS1 function with external safety
 control • 75
 STO Application examples • 75
 STO delay times • 74
 STO function test • 79
 STO function without external safety control •





77

- STO Operating Principle • 68
- STO principle of PSD1-M with three axis modules • 71
- STO principle of PSD1-M with two axis modules • 70
- STO principle of PSD1-S with one axis module • 69
- STO principle with PSD1-S • 69
- STO test protocol specimen • 80
- Supply networks • 27

T

- Technical data • 96
- Technical data STO • 81, 103
- Temperature switch mains module X40 • 64
- Tightening torque of the wiring terminals • 21, 25
- Type identification plate PSD1-M • 8
- Type identification plate PSD1-S • 8

U

- UL certification • 20, 24

V

- View from above (PSD1-M) • 47
- View from above (PSD1-S) • 33
- View from below (PSD1-M mains module) • 57
- View from below (PSD1-M) • 46
- View from below (PSD1-S) • 33

W

- Warranty conditions • 14
- What is necessary and where to find it? • 6
- Wiring of the digital inputs and outputs • 36, 51
- Wiring of the motor output filter • 89
- Working safely / qualification • 12

X

- X17
 - Digital Inputs / outputs (PSD1-S) • 35
 - Digital Inputs / outputs Axis 1 & 3 (PSD1-M) • 49
- X18 - X19 X20 feedback connector
 - Assignment with incremental encoder • 51
- X21
 - Digital Inputs / outputs Axis 2 & 3 (PSD1-M) • 50
- X4
 - Inputs / Outputs of the mains module • 64
- X40
 - Braking resistor / Temperature switch PSD1-M_P (Power supply) • 63
- X41 Mains supply (mains module PSD1-M_P) •

61

- X41 Mains supply PSD1-M_P connector assignment • 61
- X43
 - Motor Connection (PSD1M_1800) • 53
- X44
 - Connection of motor brake (PSD1M_1800) • 54
- X45
 - Motor Connection (PSD1-M) • 53
- X46
 - Connection of motor brake (PSD1-M) • 54
- X48
 - HIPERFACE DSL® & Motor temperature sensor (PSD1-M) • 54
- X51
 - Motor holding brake and HIPERFACE DSL® - Connection • 38
- X52
 - Motor Connection (PSD1-S) • 38
- X60
 - PC-/Diagnostic interface • 39, 65
- X61, X62 Ethernet Connection • 39, 65
- X63
 - AC Mains Supply, DC voltage supply & Connection of braking resistor (PSD1-S) • 36
- X9
 - Control voltage 24 VDC mains module • 60





Parker Worldwide

Europe, Middle East, Africa

AE – United Arab Emirates, Dubai
Tel: +971 4 8127100
parker.me@parker.com

AT – Austria, Wiener Neustadt
Tel: +43 (0)2622 23501-0
parker.austria@parker.com

AT – Eastern Europe, Wiener Neustadt
Tel: +43 (0)2622 23501 900
parker.easteurope@parker.com

AZ – Azerbaijan, Baku
Tel: +994 50 2233 458
parker.azerbaijan@parker.com

BE/LU – Belgium, Nivelles
Tel: +32 (0)67 280 900
parker.belgium@parker.com

BG – Bulgaria, Sofia
Tel: +359 2 980 1344
parker.bulgaria@parker.com

BY – Belarus, Minsk
Tel: +48 (0)22 573 24 00
parker.poland@parker.com

CH – Switzerland, Etoy
Tel: +41 (0)21 821 87 00
parker.switzerland@parker.com

CZ – Czech Republic, Klecany
Tel: +420 284 083 111
parker.czechrepublic@parker.com

DE – Germany, Kaarst
Tel: +49 (0)2131 4016 0
parker.germany@parker.com

DK – Denmark, Ballerup
Tel: +45 43 56 04 00
parker.denmark@parker.com

ES – Spain, Madrid
Tel: +34 902 330 001
parker.spain@parker.com

FI – Finland, Vantaa
Tel: +358 (0)20 753 2500
parker.finland@parker.com

FR – France, Contamine s/Arve
Tel: +33 (0)4 50 25 80 25
parker.france@parker.com

GR – Greece, Athens
Tel: +30 210 933 6450
parker.greece@parker.com

HU – Hungary, Budaörs
Tel: +36 23 885 470
parker.hungary@parker.com

IE – Ireland, Dublin
Tel: +353 (0)1 466 6370
parker.ireland@parker.com

IT – Italy, Corsico (MI)
Tel: +39 02 45 19 21
parker.italy@parker.com

KZ – Kazakhstan, Almaty
Tel: +7 7273 561 000
parker.easteurope@parker.com

NL – The Netherlands, Oldenzaal
Tel: +31 (0)541 585 000
parker.nl@parker.com

NO – Norway, Asker
Tel: +47 66 75 34 00
parker.norway@parker.com

PL – Poland, Warsaw
Tel: +48 (0)22 573 24 00
parker.poland@parker.com

PT – Portugal, Leca da Palmeira
Tel: +351 22 999 7360
parker.portugal@parker.com

RO – Romania, Bucharest
Tel: +40 21 252 1382
parker.romania@parker.com

RU – Russia, Moscow
Tel: +7 495 645-2156
parker.russia@parker.com

SE – Sweden, Spånga
Tel: +46 (0)8 59 79 50 00
parker.sweden@parker.com

SK – Slovakia, Banská Bystrica
Tel: +421 484 162 252
parker.slovakia@parker.com

SL – Slovenia, Novo Mesto
Tel: +386 7 337 6650
parker.slovenia@parker.com

TR – Turkey, Istanbul
Tel: +90 216 4997081
parker.turkey@parker.com

UA – Ukraine, Kiev
Tel: +48 (0)22 573 24 00
parker.poland@parker.com

UK – United Kingdom, Warwick
Tel: +44 (0)1926 317 878
parker.uk@parker.com

ZA – South Africa, Kempton Park
Tel: +27 (0)11 961 0700
parker.southafrica@parker.com

North America

CA – Canada, Milton, Ontario
Tel: +1 905 693 3000

US – USA, Cleveland
Tel: +1 216 896 3000

Asia Pacific

AU – Australia, Castle Hill
Tel: +61 (0)2-9634 7777

CN – China, Shanghai
Tel: +86 21 2899 5000

HK – Hong Kong
Tel: +852 2428 8008

IN – India, Mumbai
Tel: +91 22 6513 7081-85

JP – Japan, Tokyo
Tel: +81 (0)3 6408 3901

KR – South Korea, Seoul
Tel: +82 2 559 0400

MY – Malaysia, Shah Alam
Tel: +60 3 7849 0800

NZ – New Zealand, Mt Wellington
Tel: +64 9 574 1744

SG – Singapore
Tel: +65 6887 6300

TH – Thailand, Bangkok
Tel: +662 186 7000

TW – Taiwan, Taipei
Tel: +886 2 2298 8987

South America

AR – Argentina, Buenos Aires
Tel: +54 3327 44 4129

BR – Brazil, Sao Jose dos Campos
Tel: +55 800 727 5374

CL – Chile, Santiago
Tel: +56 2 623 1216

MX – Mexico, Toluca
Tel: +52 72 2275 4200

We reserve the right to make technical changes. The data correspond to the technical state at the time of printing.
© 2015 Parker Hannifin Corporation.
All rights reserved.



EMEA Product Information Centre

Free phone: 00 800 27 27 5374

(from AT, BE, CH, CZ, DE, DK, EE, ES, FI, FR, IE, IL, IS, IT, LU, MT, NL, NO, PL, PT, RU, SE, SK, UK, ZA)

US Product Information Centre

Toll-free number: 1-800-27 27 537

www.parker.com

Your local authorized Parker distributor

